

Ver. | - - -



IMPORTANT NOTE:

Read this manual carefully before installing or operating your new air conditioning unit. Make sure to save this manual for future reference.

Table of Contents

Part I : Technical Information	3
1. Summary	3
2. Specifications	4
2.1 Specification Sheet.....	4
3. Outline Dimension Diagram	9
4. Refrigerant System Diagram	10
5. Electrical Part	11
5.1 Wiring Diagram	11
5.2 PCB Printed Diagram	13
6. Function and Control	14
6.1 Brief Description of Models and Functions	14
7. Notes for Installation and Maintenance	15
Part II : Installation and Maintenance	15
8. Installation	19
8.1 Outline Dimension Drawings of the Indoor Unit.....	19
8.2 Dimension Requirements on the Installation Space of the Indoor Unit.....	19
8.3 Installation of the Indoor Unit.....	20
8.4 Horizontality Check of the Indoor Unit.....	21
8.5 Installation of the Air Supply Duct.....	21
8.6 Drawings of the Air Supply Outlet and Return Air Inlet.....	22
8.7 Installation of the Return Air Duct.....	22
8.8 Installation of the Condensate Pipe	23
8.9 Design of the Drain Pipe	23
8.10 Installation of the Drain Pipe	23

8.11 Precautions for the Lift Pipe	24
8.12 Test for the Drainage System	25
8.13 Piping	25
8.14 Insulation for the refrigerant pipe	26
8.15 Wiring between the Wire and the Wiring Terminal	26
8.16 Wiring of the Power Cord (single-phase)	27
9. Maintenance	28
9.1 Error Code List	28
9.2 Procedure of Troubleshooting	30
10. Exploded View and Parts List	41
11. Removal Procedure	47

1. Summary

Indoor Unit:

MV-D09BI2
MV-D12BI2
MV-D18BI2



MV-D24BI2

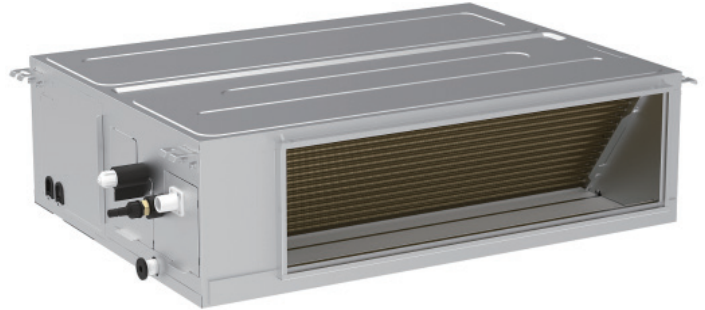

Model list:

No.	Model	Product code
1	MV-D09BI2	CF022N3660
2	MV-D12BI2	CF022N3680
3	MV-D18BI2	CF022N3650
4	MV-D24BI2	CF022N3670

2. Specifications

2.1 Specification Sheet

Parameter	Unit	Value
Model		MV-D09BI2
Product Code		CF022N3660
Power Supply	Rated Voltage	V~ 220-240
	Rated Frequency	Hz 50
	Phases	1
Cooling Capacity	W	2650
Heating Capacity	W	2800
Air flow volume	m ³ /h	560/450/340/220
Dehumidifying Volume	L/h	0.8
Fan Type		Centrifugal
Fan Diameter-height	mm	Φ138.6-143
Fan Motor Speed	rpm	Cooling:950/830/710/600 Heating:950/830/710/600
Fan Motor Power Output	W	/
Fan Motor Power Input	W	65
Motor Full Load Amp(FLA)	A	/
Fan Motor Capacitor	μF	2
Evaporator Material		Inner Groove Copper Tube- Aluminum fin
Evaporator Pipe Diameter	mm	Φ5
Evaporator Number of Rows-Fin Pitch	mm	2-1.4
Evaporator Length(L)XHeight(H)XWidth(W)	mm	547X228.6X22.8
Fuse Current	A	5
Sound Pressure Level	dB (A)	32/28/25/22
Sound Power Level	dB (A)	47/43/40/37
Dimension of Outline(LXDXH)	mm	710X450X200
Dimension of Carton Box(LXWXH)	mm	1005X565X260
Dimension of Package(LXWXH)	mm	1008X568X275
Net Weight	kg	18.5
Gross Weight	kg	22.5
Liquid pipe	inch	1/4"
Gas Pipe(to indoor unit)	inch	3/8"

The above data is subject to change without notice. Please refer to the nameplate of the unit.

Parameter	Unit	Value
Model		MV-D12BI2
Product Code		CF022N3680
Power Supply	Rated Voltage	V~ 220-240
	Rated Frequency	Hz 50
	Phases	1
Cooling Capacity	W	3500
Heating Capacity	W	4000
Air flow volume	m ³ /h	600/540/420/300
Dehumidifying Volume	L/h	1.4
Fan Type		Centrifugal
Fan Diameter-height	mm	Φ138.6-143
Fan Motor Speed	rpm	Cooling:1160/1030/930/810 Heating:1160/1030/930/810
Fan Motor Power Output	W	/
Fan Motor Power Input	W	75
Motor Full Load Amp(FLA)	A	/
Fan Motor Capacitor	μF	3.5
Evaporator Material		Inner Groove Copper Tube- Aluminum fin
Evaporator Pipe Diameter	mm	Φ5
Evaporator Number of Rows-Fin Pitch	mm	3-1.4
Evaporator Length(L)XHeight(H)XWidth(W)	mm	547X228.6X34.2
Fuse Current	A	5
Sound Pressure Level	dB (A)	36/34/31/27
Sound Power Level	dB (A)	51/49/46/42
Dimension of Outline(LXDXH)	mm	710X450X200
Dimension of Carton Box(LXWXH)	mm	1005X565X260
Dimension of Package(LXWXH)	mm	1008X568X275
Net Weight	kg	19
Gross Weight	kg	23
Liquid pipe	inch	1/4"
Gas Pipe(to indoor unit)	inch	3/8"

The above data is subject to change without notice. Please refer to the nameplate of the unit.

Parameter	Unit	Value
Model		MV-D18BI2
Product Code		CF022N3650
Power Supply	Rated Voltage	V~ 220-240
	Rated Frequency	Hz 50
	Phases	1
Cooling Capacity	W	5000
Heating Capacity	W	5500
Air flow volume	m ³ /h	800/720/610/420
Dehumidifying Volume	L/h	1.8
Fan Type		Centrifugal
Fan Diameter-height	mm	Φ138.6-143
Fan Motor Speed	rpm	Cooling:1060/920/810/700 Heating:1060/920/810/700
Fan Motor Power Output	W	/
Fan Motor Power Input	W	80
Motor Full Load Amp(FLA)	A	/
Fan Motor Capacitor	μF	3.5
Evaporator Material		Inner Groove Copper Tube- Aluminum fin
Evaporator Pipe Diameter	mm	Φ7
Evaporator Number of Rows-Fin Pitch	mm	3-1.4
Evaporator Length(L)XHeight(H)XWidth(W)	mm	847X228.6X38.1
Fuse Current	A	5
Sound Pressure Level	dB (A)	36/31/28/25
Sound Power Level	dB (A)	51/46/43/40
Dimension of Outline(LXDXH)	mm	1010X450X200
Dimension of Carton Box(LXWXH)	mm	1305X565X260
Dimension of Package(LXWXH)	mm	1308X568X275
Net Weight	kg	25
Gross Weight	kg	30
Liquid pipe	inch	1/4"
Gas Pipe(to indoor unit)	inch	1/2"

The above data is subject to change without notice. Please refer to the nameplate of the unit.

Parameter	Unit	Value
Model		MV-D24BI2
Product Code		CF022N3670
Power Supply	Rated Voltage	V~ 220-240
	Rated Frequency	Hz 50
	Phases	1
Cooling Capacity	W	7000
Heating Capacity	W	8000
Air flow volume	m ³ /h	1300/1200/1000/900
Dehumidifying Volume	L/h	2.5
Fan Type		Centrifugal
Fan Diameter-height	mm	Φ145-143
Fan Motor Speed	rpm	Cooling:1250/1100/1000/870 Heating:1250/1100/1000/870
Fan Motor Power Output	W	/
Fan Motor Power Input	W	200
Motor Full Load Amp(FLA)	A	/
Fan Motor Capacitor	μF	5
Evaporator Material		Inner Groove Copper Tube- Aluminum fin
Evaporator Pipe Diameter	mm	Φ7
Evaporator Number of Rows-Fin Pitch	mm	2-1.4
Evaporator Length(L)XHeight(H)XWidth(W)	mm	727X333.4X38.1
Fuse Current	A	5
Sound Pressure Level	dB (A)	46/42/40/36
Sound Power Level	dB (A)	61/57/55/51
Dimension of Outline(LXDXH)	mm	900X655X260
Dimension of Carton Box(LXWXH)	mm	1112X769X305
Dimension of Package(LXWXH)	mm	1115X772X320
Net Weight	kg	31
Gross Weight	kg	36
Liquid pipe	inch	1/4"
Gas Pipe(to indoor unit)	inch	5/8"

The above data is subject to change without notice. Please refer to the nameplate of the unit.

Notes:

- a. The rated cooling capacity data is measured under the following work condition: Indoor Temperature is 27°CDB, 19°CWB. Outdoor Temperature is 35°CDB. The rated heating capacity data is measured under the following work condition: Indoor Temperature is 20°CDB. Outdoor Temperature is 7°CDB, 6°CWB.
- b. The data will change with the change of products. Refer to those parameters listed on nameplate.
- c. Noise was tested in semi-silenced room, so the actual noise value will be a little higher for change of ambient.

Working Temperature Range				
	Indoor side state		Outdoor side stae	
	Dry bulb temp. °C	Wet bulb temp. °C	Dry bulb temp. °C	Wet bulb temp. °C
Rated Cooling	27	19	35	24
Max.Cooling	32	23	43	26
Rated Heating	20	15	7	6
Max.Heating	27	-	24	18

3. Outline Dimension Diagram

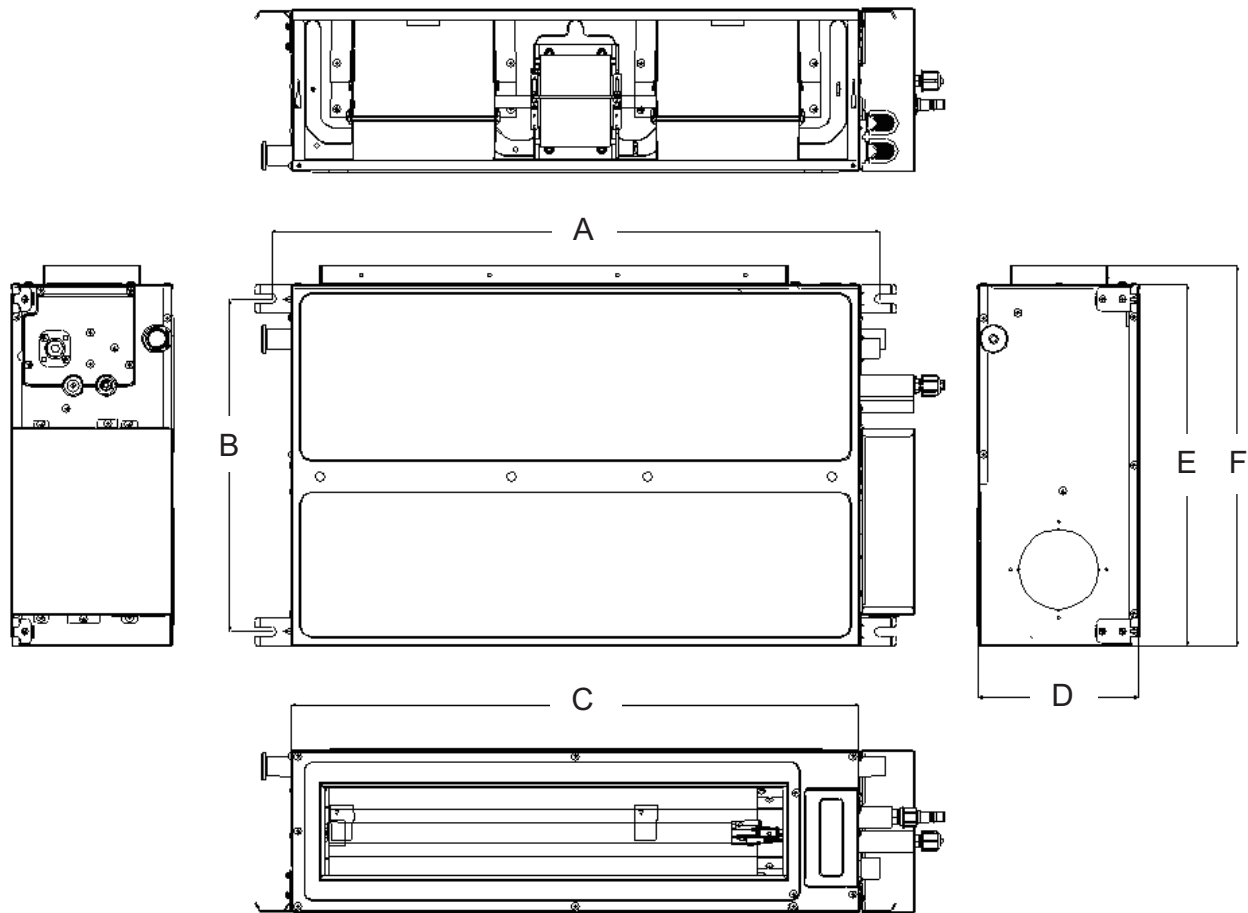

Unit: mm

Model	A	B	C	D	E	F
MV-D09/12BI2	760	415	710	200	450	474
MV-D18BI2	1060	415	1010	200	450	474
MV-D24BI2	942	530	900	260	655	685

4. Refrigerant System Diagram

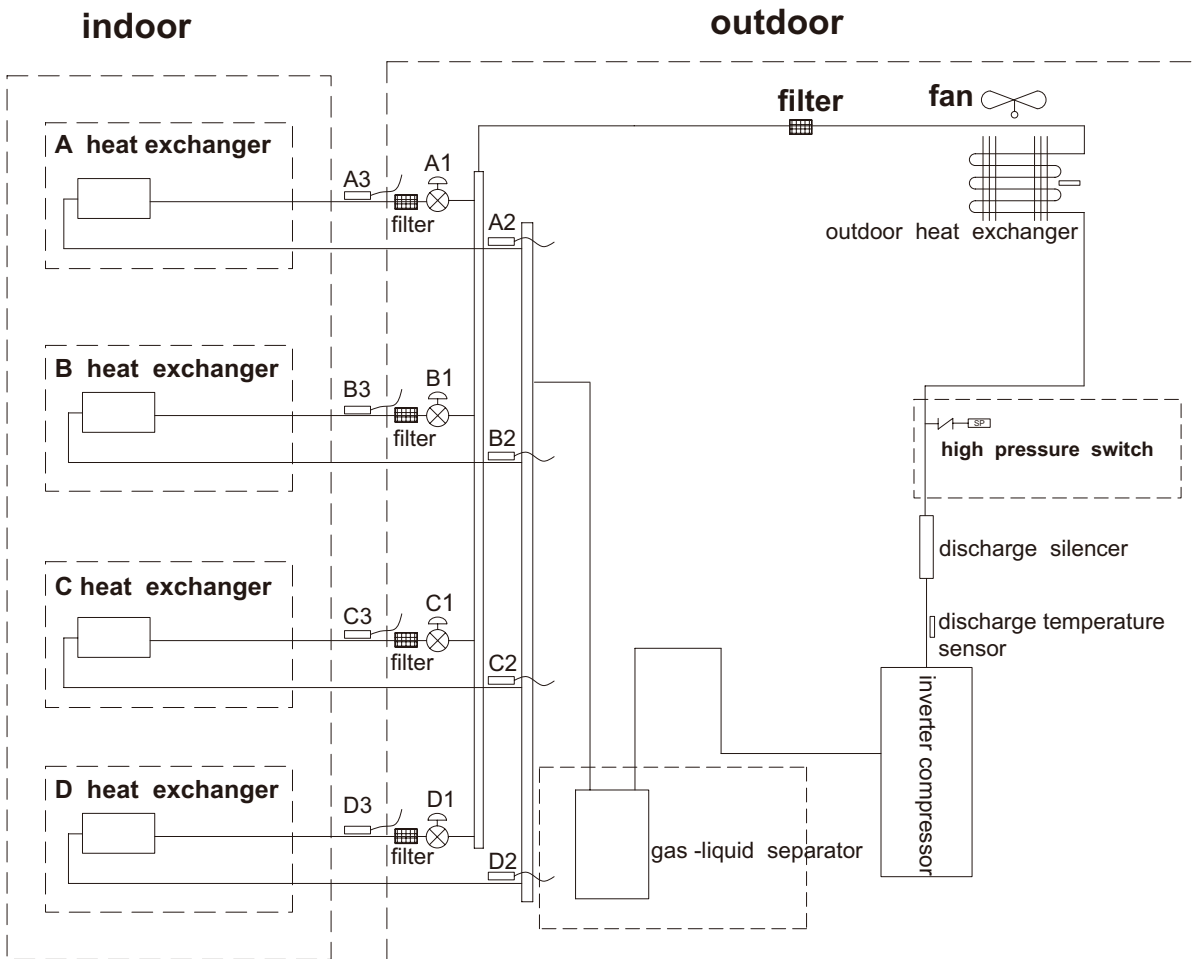

A1:A-unit electronic expansion valve **B1:B-unit electronic expansion valve**
C1:C-unit electronic expansion valve **D1:D-unit electronic expansion valve**
A2:A-unit gas pipe temperature sensor **B2:B-unit gas pipe temperature sensor**
C2:C-unit gas pipe temperature sensor **D2:D-unit gas pipe temperature sensor**
A3:A-unit liquid pipe temperature sensor **B3:B-unit liquid pipe temperature sensor**
C3:C-unit liquid pipe temperature sensor **D3:D-unit liquid pipe temperature sensor**

5. Electrical Part

5.1 Wiring Diagram

•Instruction

Symbol	Symbol Color	Symbol	Symbol Color	Symbol	Name
WH	White	GN	Green	CAP	Jumper cap
YE	Yellow	BN	Brown	COMP	Compressor
RD	Red	BU	Blue		Grounding wire
YEGN	Yellow/Green	BK	Black	/	/
VT	Violet	OG	Orange	/	/

Note: Jumper cap is used to determine fan speed and the swing angle of horizontal lover for this model.

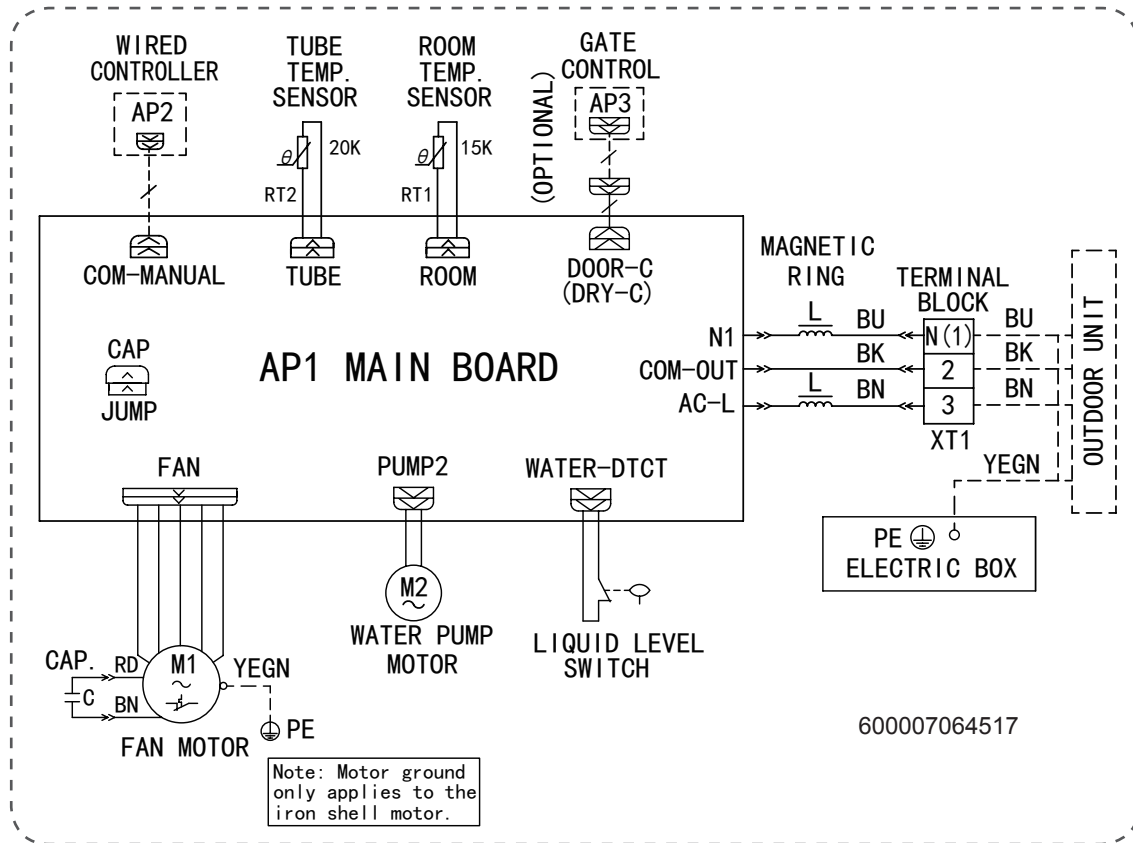

These wiring diagrams are subject to change without notice; please refer to the one supplied with the unit.

5.2 PCB Printed Diagram

MV-D09BI2, MV-D12BI2, MV-D18BI2, MV-D24BI2

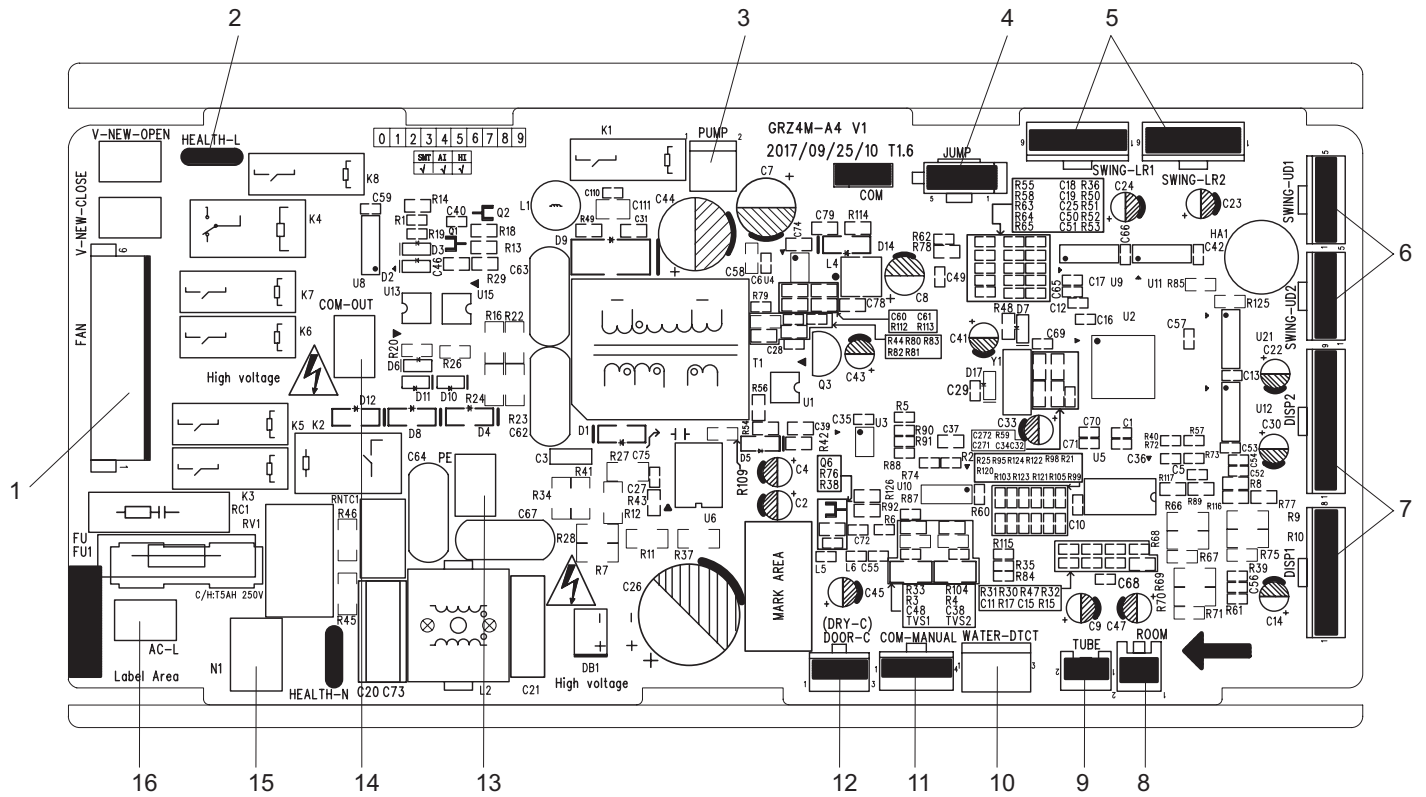

No.	Name
1	Fan terminal
2	Terminal of health function live wire
3	Water pump terminal
4	Jumper cap
5	Left&right swing terminal
6	Up&down swing terminal
7	Interface of display board
8	Ambient temperature detection terminal

No.	Name
9	Tube temperature detection terminal
10	Water full detection terminal
11	Wired controller terminal
12	Gate-control terminal
13	Grounding wire terminal
14	Communication wire terminal
15	Neutral wire terminal
16	Live wire terminal

6. Function and Control

6.1 Brief Description of Models and Functions

1. Basic function of system

(1) Cooling mode

(1) Under this mode, fan and swing operates at setting status. Temperature setting range is 16~30°C.

(2) During malfunction of outdoor unit or the unit is stopped because of protection, indoor unit keeps original operation status.

(2)Drying mode

(1) Under this mode, fan operates at low speed and swing operates at setting status. Temperature setting range is 16~30°C.

(2) During malfunction of outdoor unit or the unit is stopped because of protection, indoor unit keeps original operation status.

(3) Protection status is same as that under cooling mode.

(4) Sleep function is not available for drying mode.

(3)Heating mode

(1) Under this mode, Temperature setting range is 16~30°C.

(2) Working condition and process for heating mode:

When turn on the unit under heating mode, indoor unit enters into cold air prevention status. When the unit is stopped or at OFF status, and indoor unit has been started up just now, the unit enters into residual heat-blowing status.

(4)Working method for AUTO mode:

1. Working condition and process for AUTO mode:

a. Under AUTO mode, standard heating $T_{\text{preset}}=20^{\circ}\text{C}$ and standard cooling $T_{\text{preset}}=25^{\circ}\text{C}$. The unit will switch mode automatically according to ambient temperature.

2. Protection function

a. During cooling operation, protection function is same as that under cooling mode.

b. During heating operation, protection function is same as that under heating mode.

3. Display: Set temperature is the set value under each condition. Ambient temperature is ($T_{\text{amb.}}-T_{\text{compensation}}$) for heat pump unit and $T_{\text{amb.}}$ for cooling only unit.

4. If there's I feel function, $T_{\text{compensation}}$ is 0. Others are same as above.

(5)Fan mode

Under this mode, indoor fan operates at set fan speed. Compressor, outdoor fan, 4-way valve and electric heating tube stop operation. Indoor fan can select to operate at high, medium, low or auto fan speed. Temperature setting range is 16~30°C.

2. Other control

(1) Buzzer

Upon energization or availablely operating the unit or remote controller, the buzzer will give out a beep.

(2) Auto fan

Heating mode: During auto heating mode or normal heating mode, auto fan speed will adjust the fan speed automatically according to ambient temperature and set temperature.

(3) Sleep

After setting sleep function for a period of time, system will adjust set temperature automatically.

(4) Timer function:

General timer and clock timer functions are compatible by equipping remote controller with different functions.

(5) Memory function

memorize compensation temperature, off-peak energization value.

Memory content: mode, up&down swing, light, set temperature, set fan speed, general timer (clock timer cant be memorized).

After power recovery, the unit will be turned on automatically according to memory content.

(6)Refrigerant recovery function:

(1) Enter refrigerant recycling function

Within 5min after energizing (unit ON or OFF status is ok), continuously press LIGHT button for 3 times within 3s to enter refrigerant recycling mode; Fo is displayed and refrigerant recycling function is started. At this moment, the maintenance people closes liquid valve. After 5min, stick the thimble of maintenance valve with a tool. If there is no refrigerant spraying out, close the gas valve immediately and then turn off the unit to remove the connection pipe.

(2) Exit refrigerant recycling function

After entering refrigerant recycling mode, when receive any remote control signal or enter refrigerant recycling mode for 25min, the unit will exit refrigerant recycling mode automatically. If the unit is in standby mode before refrigerant recycling, it will be still in standby mode after finishing refrigerant recycling; if the unit is in ON status before refrigerant recycling, it will still run in original operation mode.

(7)Off-peak energization function:

Adjust compressors minimum stop time. The original minimum stop time is 180s and then we change to:

The time interval between two start-ups of compressor cant be less than $180+T$ s ($0 \leq T \leq 15$). T is the variable of controller. That's to say the minimum stop time of compressor is 180s~195s. Read-in T into memory chip when refurbish the memory chip each time. After power recovery, compressor can only be started up after $180+T$ s at least.

(8) X-fan mode

When X-fan function is turned on, after turn off the unit, indoor fan will still operate at low speed for 2min and then the complete unit will be turned off. When x-fan function is turned off, after turn off the unit, the complete unit will be turned off directly.

(9) 8° heating function

Under heating mode, you can set 8° heating function by remote controller. The system will operate at 8° set temperature.

(10) Turbo fan control function

Set turbo function under cooling or heating mode to enter into turbo fan speed. Press fan speed button to cancel turbo wind.

No turbo function under auto, dry or fan mode.

7. Notes for Installation and Maintenance

Safety Precautions: Important!

Please read the safety precautions carefully before installation and maintenance.

The following contents are very important for installation and maintenance.

Please follow the instructions below.

- The installation or maintenance must accord with the instructions.
- Comply with all national electrical codes and local electrical codes.
- Pay attention to the warnings and cautions in this manual.
- All installation and maintenance shall be performed by distributor or qualified person.
- All electric work must be performed by a licensed technician according to local regulations and the instructions given in this manual.
- Be caution during installation and maintenance. Prohibit incorrect operation to prevent electric shock, casualty and other accidents.



WARNINGS

Electrical Safety Precautions:

1. Cut off the power supply of air conditioner before checking and maintenance.
2. The air condition must apply specialized circuit and prohibit share the same circuit with other appliances.
3. The air conditioner should be installed in suitable location and ensure the power plug is touchable.
4. Make sure each wiring terminal is connected firmly during installation and maintenance.
5. Have the unit adequately grounded. The grounding wire Can't be used for other purposes.
6. Must apply protective accessories such as protective boards, cable-cross loop and wire clip.
7. The live wire, neutral wire and grounding wire of power supply must be corresponding to the live wire, neutral wire and grounding wire of the air conditioner.
8. The power cord and power connection wires Can't be pressed by hard objects.
9. If power cord or connection wire is broken, it must be replaced by a qualified person.
10. If the power cord or connection wire is not long enough, please get the specialized power cord or connection wire from the manufacture or distributor. Prohibit prolong the wire by yourself.

11. For the air conditioner without plug, an air switch must be installed in the circuit. The air switch should be all-pole parting and the contact parting distance should be more than 3mm.

12. Make sure all wires and pipes are connected properly and the valves are opened before energizing.

13. Check if there is electric leakage on the unit body. If yes, please eliminate the electric leakage.

14. Replace the fuse with a new one of the same specification if it is burnt down; dont replace it with a cooper wire or conducting wire.

15. If the unit is to be installed in a humid place, the circuit breaker must be installed.

Installation Safety Precautions:

1. Select the installation location according to the requirement of this manual.(See the requirements in installation part)
2. Handle unit transportation with care; the unit should not be carried by only one person if it is more than 20kg.
3. When installing the indoor unit and outdoor unit, a sufficient fixing bolt must be installed; make sure the installation support is firm.
4. Ware safety belt if the height of working is above 2m.
5. Use equipped components or appointed components during installation.
6. Make sure no foreign objects are left in the unit after finishing installation.

Refrigerant Safety Precautions:

1. When refrigerant leaks or requires discharge during installation, maintenance, or disassembly, it should be handled by certified professionals or otherwise in compliance with local laws and regulations.
- 2.Avoid contact between refrigerant and fire as it generates poisonous gas; Prohibit prolong the connection pipe by welding.
3. Apply specified refrigerant only. Never have it mixed with any other refrigerant. Never have air remain in the refrigerant line as it may lead to rupture or other hazards.
4. Make sure no refrigerant gas is leaking out when installation is completed.
5. If there is refrigerant leakage, please take sufficient measure to minimize the density of refrigerant.
6. Never touch the refrigerant piping or compressor without wearing glove to avoid scald or frostbite.

Improper installation may lead to fire hazard, explosion, electric shock or injury.

Safety Precautions for Installing and Relocating the Unit:

To ensure safety, please be mindful of the following precautions.

WARNINGS

1. When installing or relocating the unit, be sure to keep the refrigerant circuit free from air or substances other than the specified refrigerant.

Any presence of air or other foreign substance in the refrigerant circuit will cause system pressure rise or compressor rupture, resulting in injury.

2. When installing or moving this unit, do not charge the refrigerant which is not comply with that on the nameplate or unqualified refrigerant.

Otherwise, it may cause abnormal operation, wrong action, mechanical malfunction or even series safety accident.

3. When refrigerant needs to be recovered during relocating or repairing the unit, be sure that the unit is running in cooling mode. Then, fully close the valve at high pressure side (liquid valve). About 30-40 seconds later, fully close the valve at low pressure side (gas valve), immediately stop the unit and disconnect power. Please note that the time for refrigerant recovery should not exceed 1 minute.

If refrigerant recovery takes too much time, air may be sucked in and cause pressure rise or compressor rupture, resulting in injury.

4. During refrigerant recovery, make sure that liquid valve and gas valve are fully closed and power is disconnected before detaching the connection pipe.

If compressor starts running when stop valve is open and connection pipe is not yet connected, air will be sucked in and cause pressure rise or compressor rupture, resulting in injury.

5. When installing the unit, make sure that connection pipe is securely connected before the compressor starts running.

If compressor starts running when stop valve is open and connection pipe is not yet connected, air will be sucked in and cause pressure rise or compressor rupture, resulting in injury.

6. Prohibit installing the unit at the place where there may be leaked corrosive gas or flammable gas.

If there leaked gas around the unit, it may cause explosion and other accidents.

7. Do not use extension cords for electrical connections. If the electric wire is not long enough, please contact a local service center authorized and ask for a proper electric wire.

Poor connections may lead to electric shock or fire.

8. Use the specified types of wires for electrical connections between the indoor and outdoor units. Firmly clamp the wires so that their terminals receive no external stresses.

Electric wires with insufficient capacity, wrong wire connections and insecure wire terminals may cause electric shock or fire.

Safety Precautions for Refrigerant

- To realize the function of the air conditioner unit, a special refrigerant circulates in the system. The used refrigerant is the fluoride R32, which is specially cleaned. The refrigerant is flammable and odorless. Furthermore, it can lead to explosion under certain conditions. But the flammability of the refrigerant is very low. It can be ignited only by fire.
- Compared to common refrigerants, R32 is a nonpolluting refrigerant with no harm to the ozone layer. The influence upon the greenhouse effect is also lower. R32 has got very good thermodynamic features which lead to a really high energy efficiency. The units therefore need a less filling.

WARNING:

- Do not use means to accelerate the defrosting process or to clean, other than those recommended by the manufacturer. Should repair be necessary, contact your nearest authorized Service Centre. Any repairs carried out by unqualified personnel may be dangerous. The appliance shall be stored in a room without continuously operating ignition sources. (for example: open flames, an operating gas appliance or an operating electric heater.)
- Do not pierce or burn.
- Appliance shall be installed, operated and stored in a room with a floor area larger than X m².
- Appliance filled with flammable gas R32. For repairs, strictly follow manufacturer's instructions only. Be aware that refrigerants do not contain odor.
- Read specialist manual.

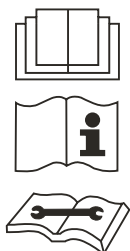

Safety Operation of Flammable Refrigerant

Qualification requirement for installation and maintenance man

- All the work men who are engaged in the refrigeration system should bear the valid certification awarded by the authoritative organization and the qualification for dealing with the refrigeration system recognized by this industry. If it needs other technician to maintain and repair the appliance, they should be supervised by the person who bears the qualification for using the flammable refrigerant.
- It can only be repaired by the method suggested by the equipment manufacturer.

Installation notes

- The air conditioner is not allowed to use in a room that has running fire (such as fire source, working coal gas stove, operating heater).
 - It is not allowed to drill hole or burn the connection pipe.
 - The air conditioner must be installed in a room that is larger than the minimum room area.
- The minimum room area is shown on the nameplate or following table a.
- Leak test is a must after installation.

table a - Minimum room area (m²)

Charge amount (kg)	floor location	window mounted	wall mounted	ceiling mounted
≤1.2	/	/	/	/
1.3	14.5	5.2	1.6	1.1
1.4	16.8	6.1	1.9	1.3
1.5	19.3	7	2.1	1.4
1.6	22	7.9	2.4	1.6
1.7	24.8	8.9	2.8	1.8
1.8	27.8	10	3.1	2.1
1.9	31	11.2	3.4	2.3
2	34.3	12.4	3.8	2.6
2.1	37.8	13.6	4.2	2.8
2.2	41.5	15	4.6	3.1
2.3	45.4	16.3	5	3.4
2.4	49.4	17.8	5.5	3.7
2.5	53.6	19.3	6	4

Maintenance notes

- Check whether the maintenance area or the room area meet the requirement of the nameplate.
 - Its only allowed to be operated in the rooms that meet the requirement of the nameplate.
- Check whether the maintenance area is well-ventilated.
 - The continuous ventilation status should be kept during the operation process.
- Check whether there is fire source or potential fire source in the maintenance area.
 - The naked flame is prohibited in the maintenance area; and the “no smoking” warning board should be hanged.
- Check whether the appliance mark is in good condition.
 - Replace the vague or damaged warning mark.

Welding

- If you should cut or weld the refrigerant system pipes in the process of maintaining, please follow the steps as below:
 - a. Shut down the unit and cut power supply
 - b. Eliminate the refrigerant
 - c. Vacuuming
 - d. Clean it with N₂ gas
 - e. Cutting or welding

f. Carry back to the service spot for welding

- Make sure that there isn't any naked flame near the outlet of the vacuum pump and it's well-ventilated.
- The refrigerant should be recycled into the specialized storage tank.

Filling the refrigerant

- Use the refrigerant filling appliances specialized for R32. Make sure that different kinds of refrigerant won't contaminate with each other.
- The refrigerant tank should be kept upright at the time of filling refrigerant.
- Stick the label on the system after filling is finished (or haven't finished).
- Don't overfilling.
- After filling is finished, please do the leakage detection before test running; another time of leak detection should be done when it's removed.

Safety instructions for transportation and storage

- Please use the flammable gas detector to check before unload and open the container.
- No fire source and smoking.
- According to the local rules and laws.

8. Installation

8.1 Outline Dimension Drawings of the Indoor Unit

Note: the unit in the followings figures is mm, unless otherwise specified.

Fig.1 is applicable to

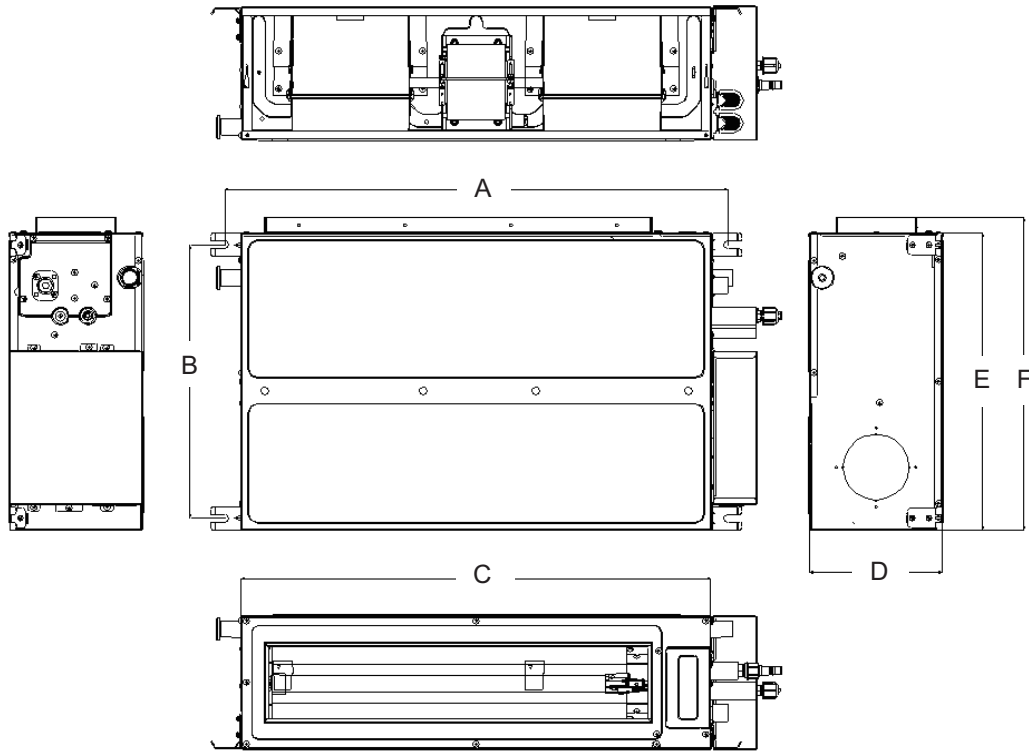

Fig.1

Unit: mm

Model	A	B	C	D	E	F
MV-D09/12BI2	760	415	710	200	450	474
MV-D18BI2	1060	415	1010	200	450	474
MV-D24BI2	942	530	900	260	655	685

8.2 Dimension Requirements on the Installation Space of the Indoor Unit

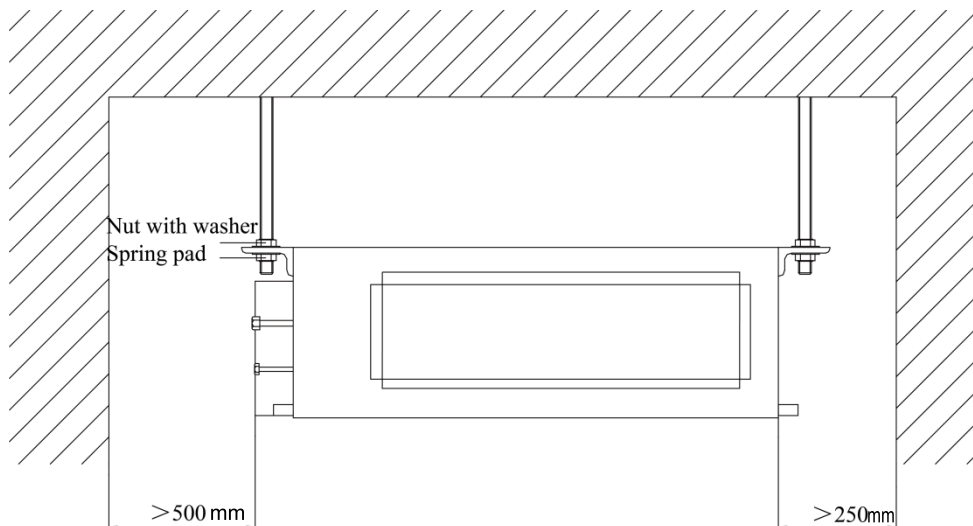

Fig. 2

8.3 Installation of the Indoor Unit

a. Requirements on the Installation Location

- 1) Ensure the hanger is strong enough to withstand the weight of the unit.
- 2) The drainage of the drain pipe is easy.
- 3) No obstacle is in the inlet/outlet and the air circulation is in good condition.
- 4) Ensure the installation space shown in Fig.2 is left for the access to maintenance.
- 5) It should be far away from where there is heat source, leakage of inflammable, explosive substances, or smog.
- 6) It is the ceiling type unit (concealed in the ceiling).
- 7) The power cords and connection lines of the indoor and outdoor units must be at least 1m away from the TV set or radio to avoid the image interference and noise (even if 1m is kept, the noise may be produced due to the strong electric wave).

b. Installation of the Indoor Unit

- 1) Insert the M10 expansion bolt into the hole, and then knock the nail into the bolt. Refer to the Outline Dimension Drawings of the Indoor Unit for the distance between holes and see Fig.3 for the installation of the expansion bolt.

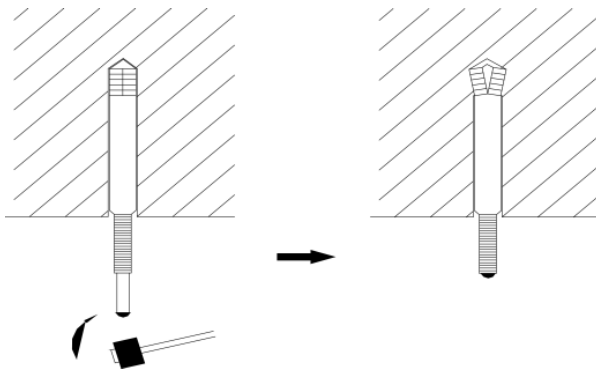

Fig. 3

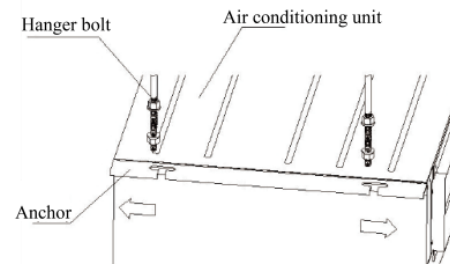

Fig. 4

Install the hanger on the indoor unit, as shown in Fig.4.

Install the indoor unit on the ceiling, as shown in Fig.5.

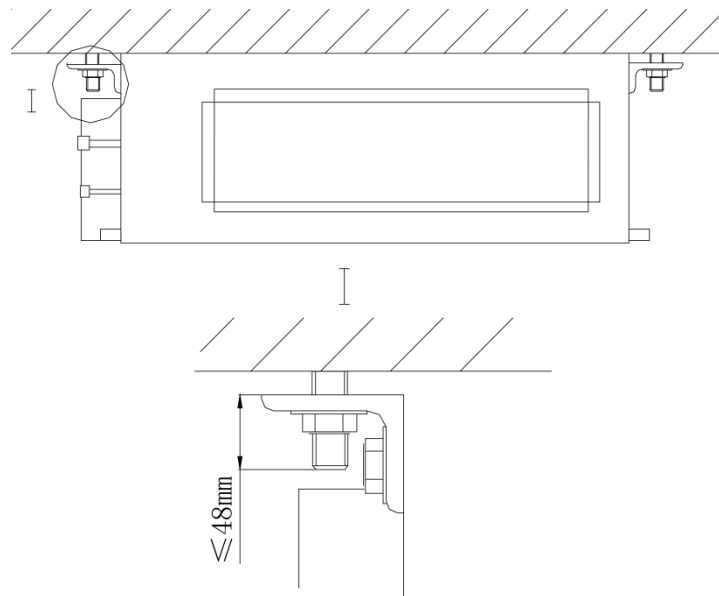

Fig. 5

⚠ CAUTION!

1. Prior to the installation, please make a good preparation for all piping (refrigerant pipe, drain pipe) and wiring (wires of the wired controller, wires between the indoor and outdoor unit) of the indoor unit to make the further installation much easier.
2. If there is an opening in the ceiling, it is better to reinforce it to keep it flat and prevent it vibrating. Consult the user and builder for more details.
3. If the strength of the ceiling is not strong enough, a beam made of angle iron can be used and then fix the unit on it.
4. If the indoor unit is not installed in the air conditioning area, please use sponge around the unit to prevent condensing. The thickness of the sponge depends on the actual installation environment.

8.4 Horizontality Check of the Indoor Unit

After the installation of the indoor unit, its horizontality must be checked to make sure the unit keep horizontal fore and aft and keep an inclination of 5° toward the drain pipe right and left, as shown in Fig.6.

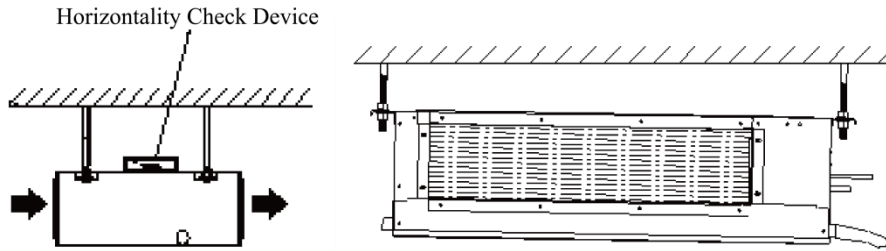

Fig. 6

8.5 Installation of the Air Supply Duct

a. Installation of the Rectangular Air Supply Duct

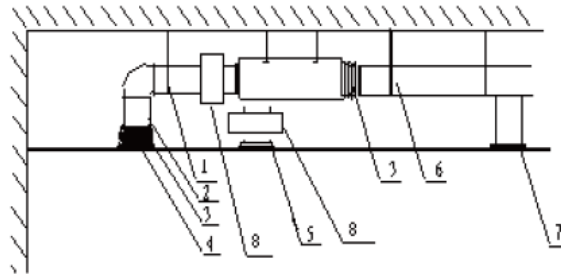
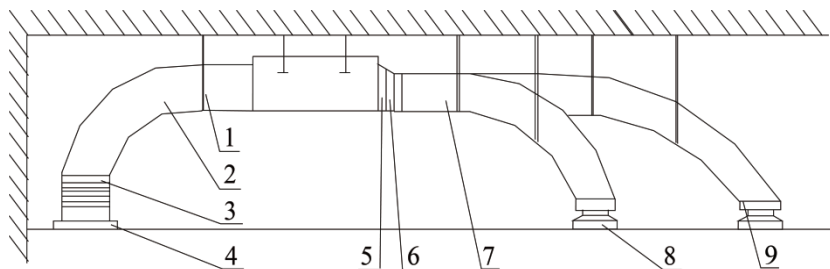

Fig. 7

No.	Name	No.	Name
1	Hanger	5	Filter Screen
2	Return Air Duct	6	Main Air Supply Duct
3	Canvas Duct	7	Air Supply Outlet
4	Return Air Inlet	8	Plenum Box

b. Installation of the Round Air Supply Duct



No.	Name	No.	Name
1	Hanger	6	Transition Duct
2	Return Air Duct	7	Air Supply Duct
3	Canvas Duct	8	Diffuser
4	Return Air Louver	9	Diffuser Joint
5	Air Supply Outlet		

c. Installation Steps of the Round Air Supply Duct

- 1) Preinstall the outlet of the round duct on the transition duct and then fix it by the self-tapping screw.
- 2) Place the transition duct to the air outlet of the unit and fix it with rivet.
- 3) Connect the outlet to the duct and then tighten them with tape. Other installation details are not covered herein.

⚠ CAUTION!

1. The maximum length of the duct means the maximum length of the air supply duct plus the maximum length of the return air duct.
2. For the unit with the auxiliary electric heating function, if the round duct is to be adopted, then the straight length of the transition duct can not be less than 200mm.
3. The duct is either rectangular or round and connected with the air inlet/outlet of the indoor unit. Among all air supply outlets, at least one should be kept open. As for the round duct, it needs a transition duct of which the size should match with the air supply outlet of the unit. After the fitting of the transition duct, it is the turn of the round duct, which is better to be kept 10 meters far away from the corresponding diffuser. The standard accessories supplied is the transition duct 200mm long and round air outlet $\phi 200$, however, those of other specifications can be purchased.

8.6 Drawings of the Air Supply Outlet and Return Air Inlet

capacity:2.5~6.0kW

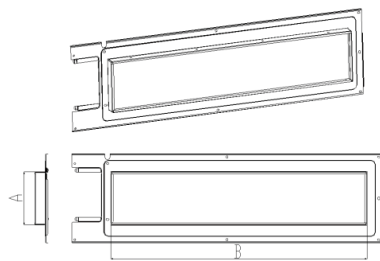

Fig.9 Air Supply Outlet

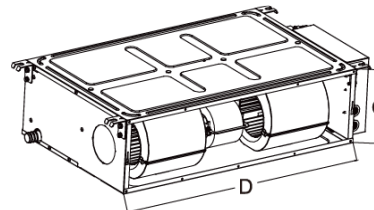

Fig.10 Return Air Inlet

Dimensions of the Air Supply Outlet and Return Air Inlet (unit: mm)

Model	Item	Dimension of air outlet flange		Dimension of air return	
		A	B	C	D
09K/12K		122	585	200	710
18K		122	885	200	1010
24K		219	743	260	900

8.7 Installation of the Return Air Duct

- a. The default installation location of the rectangular flange is in the back and the return air cover plate is in the bottom, as shown in Fig.11.

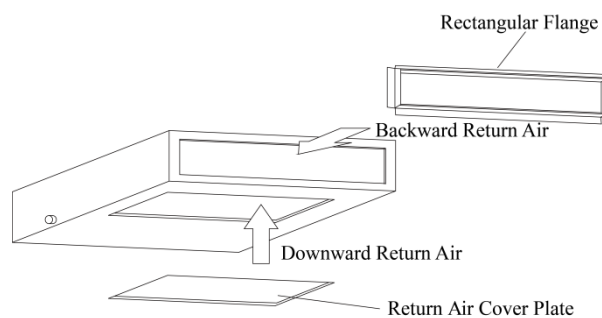

Fig.11

- b. If the downward return air is desired, just change the place of the rectangular flange and the return air cover plate.
- c. Connect one end of the return air duct to the return air outlet of the unit by rivets and the other to the return air louver. For the sake of the convenience to freely adjust the height, a cutting of canvas duct will be helpful, which can be reinforce and folded by 8 # iron wire.
- d. More noise is likely to be produced in the downward return air mode than the backward return air mode, so it is suggestive to install a silencer and a plenum box to minimize the noise.
- e. The installation method can be chose with considering the conditions of the building and maintenance etc., as shown in Fig.12.

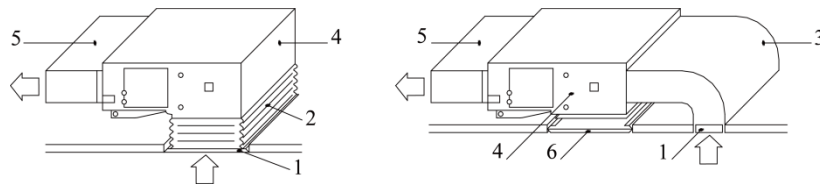

Fig.12

Parts and Components of the Return Air Duct

No.	Name	No.	Name
1	Return Air Louver(with the filter screen)	4	Indoor Unit
2	Canvas Duct	5	Air Supply Duct
3	Return Air Duct	6	Access Grille

8.8 Installation of the Condensate Pipe

a. The condensate pipe should keep a inclination angle of 5~10°, which can facilitate the drainage of the condensate water. And the joints of the condensate pipe should be insulated by the insulation material to prevent condensing(see Fig.13).

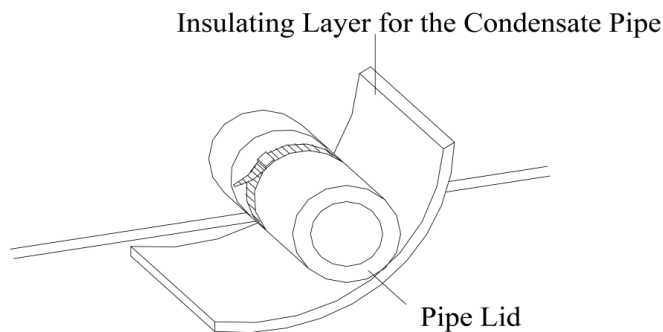

Fig.13 Thermal Insulation of the Condensate Pipe

b. There is a condensate outlet on both left and right sides of the unit. Once one is confirmed to be used, the other should be clogged by a rubber plug, bundled by the binding wire and insulated by the insulation material to avoid water leakage.

c. The right outlet is defaulted to be clogged with a plug.

⚠ CAUTION!

No water leakage is allowed on the joint of the condensate pipe.

8.9 Design of the Drain Pipe

a. The drain pipe should always keep an inclination angle(1/50~1/100) to avoid the water gathering in some certain place.

b. During the connection of the drain pipe and device, do not impose too much force on the pipe on one side of the device and the pipe should be fixed as close as to the device.

c. The drain pipe can be the ordinary hard PVC pipe which can be purchased locally. During the connection, inset the end of the PVC pipe to the drain outlet, then tighten it with the drain hose and binding wire but never connect the drain outlet and the drain hose by adhesive.

d. When the drain pipe is used for multiple devices, the public section of the pipe should be 100mm lower than the drain hole of each device and it is better to use the much thicker pipe for such a purpose.

8.10 Installation of the Drain Pipe

a. The diameter of the drain pipe should be larger or equal to that of the refrigerant pipe (PVC pipe, outer diameter:25mm, wall thickness≥1.5mm).

b. The drain pipe should be as short as possible and with at least a 1/100 degree of slope to avoid forming air pockets.

c. If the proper degree of slope of the drain pipe is not allowed, a lift pipe should be installed.

d. A distance 1-1.5m should be kept between the hangers to avoid the drain hose making a turn.

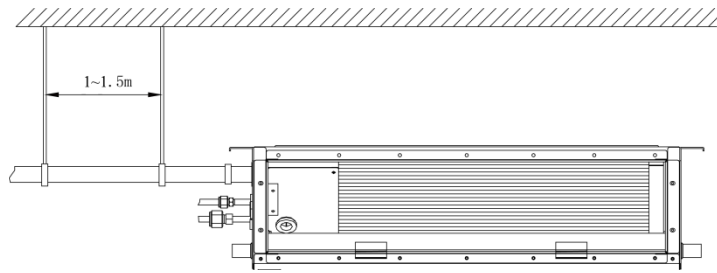

(Right) with a min. degree of slope 1/100

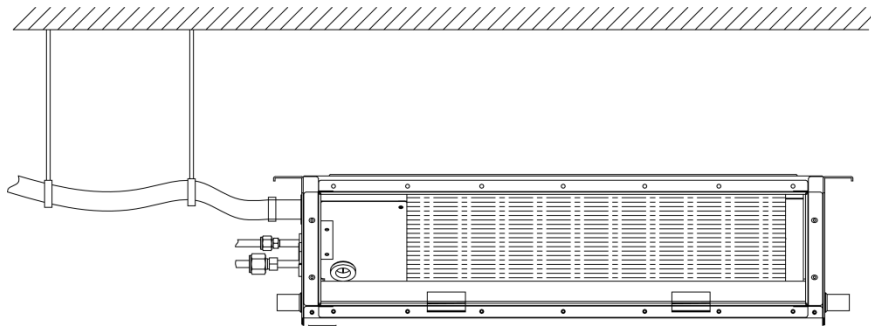

(Wrong)

Fig.14

- e. Insert the drain hose into the drain hole and tighten it with clamps.
- f. Wrap the clamps with large amount of sponge for thermal insulation.
- g. The drain hose inside the room also should be insulated.

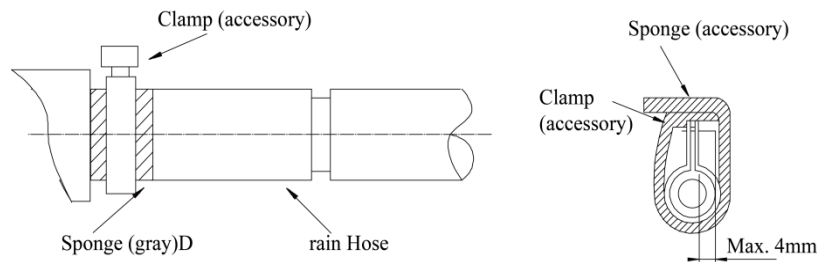

Fig.15

8.11 Precautions for the Lift Pipe

The installation height of the lift pipe should be less than 850mm. It is recommended to set an inclination angle $1^{\circ}\sim 2^{\circ}$ for the lift pipe toward the drainage direction. If the lift pipe and the unit form a right angle, the height of the lift pipe must be less than 800mm.

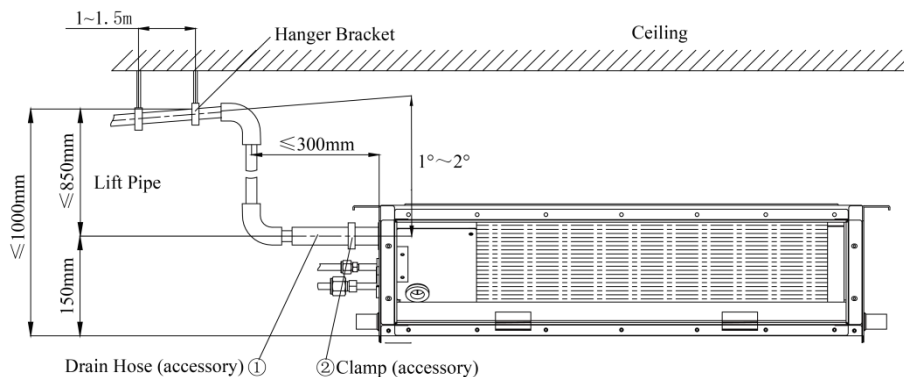
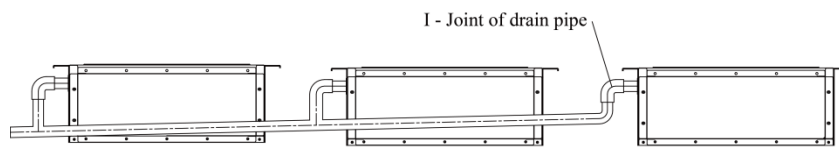

Fig.16

Notes:

1. The inclination height of the drain hose should be within 75mm so that the outlet of the drain hose does not suffer the external force.
2. If multiple drain pipes converge, please follow the installation steps below.



The specification of the joint of the drain pipe should be suitable to the running capacity of the unit

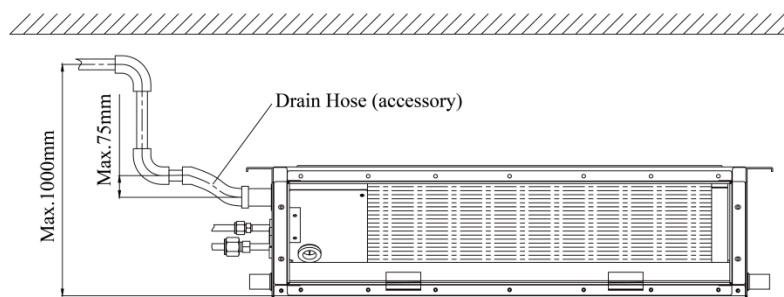

Fig.17

8.12 Test for the Drainage System

- a. After the electric installation, please take a test for the drainage system.
- b. During the test, check if the water flow goes through the pipe correctly and observe carefully the joint to see if it leaks or not. If this unit is installed in the newly built house, it is suggested to take this test prior to the ceiling decoration.

8.13 Piping

- a. Let the flare end of the copper pipe point at the screw and then tighten the screw by hand.
- b. After that, tighten the screw by the torque wrench unit it clatters (as shown in Fig.18).

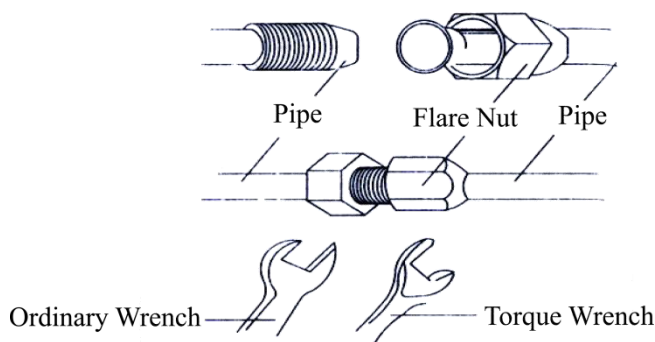

Fig.18

Moments of Torque for Tightening Screws

Diameter of Pipe(mm)	Moment of Torque (N·m)
Φ 6.35(1/4)	15-30
Φ 9-9.52(3/8)	35-40
Φ 12(1/2)	45-50
Φ 15.9(5/8)	60-65

- a. The bending degree of the pipe can not be too small; otherwise it will crack. And please use a pipe bender to bend the pipe.
- b. Wrap the exposed refrigerant pipe and the joints by sponge and then tighten them with the plastic tape.

⚠ CAUTION!

1. During the connection of the indoor unit and the refrigerant pipe, never pull any joints of the indoor unit by force; otherwise the capillary pipe or other pipe may crack, which then would result in leakage.
2. The refrigerant pipe should be supported by brackets, that is, don't let the unit withstand the weight of it.

8.14 Insulation for the refrigerant pipe

- a. The refrigerant pipe should be insulated by the insulating material and plastic tape in order to prevent condensing and leaking.
- b. The joints of the indoor unit should be wrapped with the insulating material and no gas is allowed on the joint of the indoor unit, as shown in Fig.19.

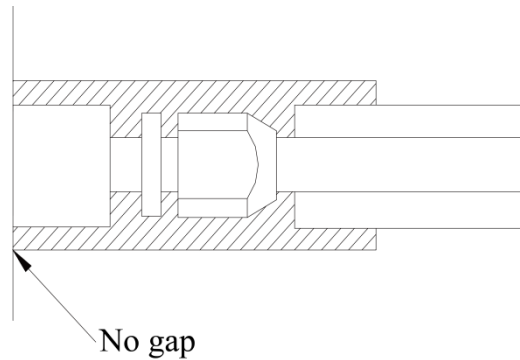

Fig.19

⚠ CAUTION!

After the pipe is protected well enough, never bend it to form a small angle; otherwise it would crack or break.

c. Wrapping the pipe with tape.

- 1) Bundle the refrigerant pipe and electric wire together with tape, and separate them from the drain pipe to prevent the condensate water overflowing.
- 2) Wrap the pipe from the bottom of the outdoor unit to the top of the pipe where it enters the wall. During the wrapping, the later circle should cover half of the former one.
- 3) Fix the wrapped pipe on the wall with clamps.

⚠ CAUTION!

1. Do not wrap the pipe too tightly; otherwise the insulation effect would be weakened. Additionally, make sure the drain hose is separated from the pipe
2. After that, fill the hole on the wall with sealing material to prevent wind and rain coming into the room.

8.15 Wiring between the Wire and the Wiring Terminal

a. Wiring of the Single-Core Wire

- 1) Strip the insulating layer at the end of the wire about 25mm off with a wire stripper.
- 2) Loosen the screw off on the wiring board of the air conditioning unit.
- 3) Shape with the pliers the end of the wire to a circle matching with the size of the screw.
- 4) Let the screw go through the circle of the wire and then fix it on the wiring board.

b. Wiring of the Multi-Core Wire

- 1) Strip the insulating layer at the end of the wire about 10mm off with a wire stripper.
- 2) Loosen the screw off on the wiring board of the air conditioning unit.
- 3) Fix a wiring terminal matching with the size of the screw to the end of the multi-core wire with the crimping pliers.
- 4) Let the screw go through the terminal of the multi-core wire and then fix it on the wiring board.

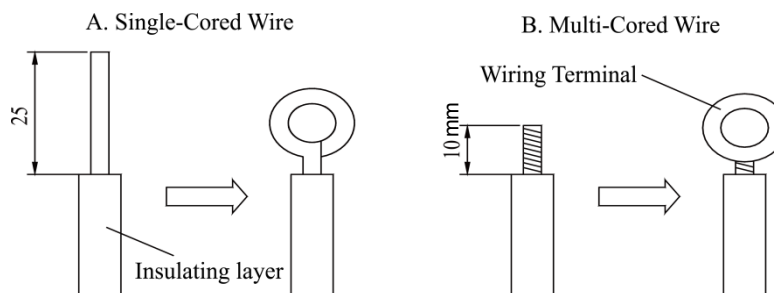

Fig.20

⚠ WARNING!

1. If the power cord is damaged, they must be replaced with the dedicated one.
2. Prior to the wiring, please check the voltage marked on the nameplate and then carries out the wiring following the wiring diagram.
3. The dedicated power cord must be used for the air conditioning unit and the leakage current protection switch and air switch must be installed in case of the overload condition.
4. The air conditioning unit must be earthed to prevent the hazard caused by the failed insulation.
5. During the wiring, the wiring terminal or the single-core wire must be used; the direct wiring between the multi-core wire and wiring board would cause fire.
6. All wiring should be done strictly in accordance with the wiring diagram; otherwise the improper wiring would cause the air conditioning unit running abnormally or damaged.
7. Do not let the electric wires touch the refrigerant pipe, the compressor, the fan or other moving parts.
8. Do not modify the wiring inside the indoor unit randomly; otherwise the manufacturer won't assume any responsibility for the damage or abnormal running of the unit.

8.16 Wiring of the Power Cord (single-phase)

⚠ CAUTION!

The power supply for each indoor unit must be uniform.

1. Dismantle the cover of the electric box of the indoor unit.
2. Let the power cord go through the rubber ring.
3. Connect the wiring (communication) through the piping hole of the chassis and the bottom of the appliance upward, then connect the brown wire to the Terminal board "3";black wire(the communication wire) to the Terminal board"2";blue wire to the Terminal board"N(1)",and connect the earthing wire to the screw terminal on the electric box. Clamp them with the corresponding wire clamp packed in the chassis.
4. Fix the power cord tightly with the binding wire.

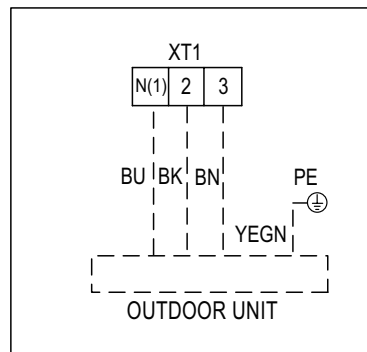

Fig.21

9. Maintenance

9.1 Error Code List

NO.	Name of malfunction	Double 8 code display	AC status	Malfunctions
1	Indoor ambient sensor open circuit, short circuit	F1	Cooling dehumidifying; indoor fan motor is running, other overloads will stop; Heating whole unit will stop to run.	1. Room temp.sensor is not connected with the control panel AP1 2. Room temp.sensor is damaged
2	Indoor evaporator sensor open circuit, short circuit	F2	Cooling dehumidifying; indoor fan motor is running, other overloads will stop; Heating whole unit will stop to run.	1. Tube temp.sensor is not connected with the control panel AP1 2. Tube temp.sensor is damaged
3	Indoor and outdoor units communication malfunction	E6	Cooling,compressor will stop,indoor fan motor works,Heating:all will stop	Please refer to troubleshooting
4	In defect of refrigerant	F0	The Dual-8 Code Display will show F0 and the complete unit stops.	1. In defect of refrigerant; 2. Indoor evaporator temperature sensor works abnormally; 3. The unit has been plugged up somewhere.
5	Full water protection	E9	Water level switch	If cut-off of water level switch is detected for 8s successively once energized, the system will enter full water protection. In this case, switch off the unit and then switch it on to eliminate this malfunction.
6	Internal motor (fan motor) do not operate	H6	Internal fan motor, external fan motor, compressor and electric heater stop operation, guide louver stops at present location.	1. Bad contact of DC motor feedback terminal. 2. Bad contact of DC motor control end. 3. Fan motor is stalling. 4. Motor malfunction. 5. Malfunction of mainboard revdetecting circuit.
7	Malfunction of zero-crossing signal of indoor unit	U8	Compressor, outdoor fan and indoor fan stop operation.	1. The power is abnormal; 2. Main board of indoor unit is damaged.
8	High pressure protection of system	E1	During cooling and drying operation, except indoor fan operates, all loads stop operation. During heating operation, the complete unit stops.	Possible reasons: 1. Refrigerant was superabundant; 2. Poor heat exchange (including filth blockage of heat exchanger and bad radiating environment); Ambient temperature is too high.
9	Anti-freezing protection for evaporator	E2	Not the error code. It's the status code for the operation.	
10	System block or refrigerant leakage	E3	The Dual-8 Code Display will show E3 until the low pressure switch stop operation.	1.Low-pressure protection 2.Low-pressure protection of system 3.Low-pressure protection of compressor
11	Compressor air exhaust high temp. protection	E4	cooling,dehumidifying,compressor,outdoor fan motor will stop running,indoor fan motor works. heating:all stop running.	Pls refer to trouble shoot (air exhaust protection,overload)
12	AC overload protection	E5	Cooling,dehumidifying,compressor,outdoor fan motor will stop,indoor fan will work.heating;all will stop	1.power supply is stable,fluctuation is too much 2.Power supply is too low,overload is too much.
13	Indoor and outdoor units communication malfunction	E6	Cooling,compressor will stop,indoor fan motor works,Heating:all will stop	Please refer to troubleshooting
14	Anti-high temp. protection	E8	Cooling,compressor will stop,indoor fan motor works,Heating:all will stop	Please refer to troubleshooting

NO.	Name of malfunction	Double 8 code display	AC status	Malfunctions
15	Outdoor ambient sensor circuit open,circuit short	F3	Cooling,dehumidifying;compressor will stop,indoor fan motor will work.Heat:all will stop	Outdoorroom temp.sensor hasn't connected well,or damaged,please refer to the sensor resistance value for checking.
16	Outdoor condensor sensor open circuit,short circuit	F4	Cooling,dehumidifyin-g;compressor will stop,indoor fan motor will work.Heat:all will stop	Outdoorroom temp.sensor hasn't connected well,or damaged,please refer to the sensor resistance value for checking.
17	Outdoor air exhaust sensor open circuit,short circuit	F5	Cooling,dehumidifying;after runing for 3mins later,the compressor will stop to run,indoor fan motor will start to run.heating:after run 3 mins later,all will stop to run.	1.Exhaust temp sensor hasn't connected well,or damaged,plwase refer to the sensor resistance value for checking. 2.Sensor head hasn't insert into the copper tube.
18	Malfunction protection of jumper cap	C5	Wireless remote receiver and button are effective, but can not dispose the related command.	1. No jumper cap insert on mainboard. 2. Incorrect insert of jumper cap. 3. Jumper cap damaged. 4. Abnormal detecting circuit of mainboard.

9.2 Procedure of Troubleshooting

1. Malfunction of Temperature Sensor F1, F2

Main detection points:

- Is the wiring terminal between the temperature sensor and the controller loosened or poorly contacted?
- Is there short circuit due to trip-over of the parts?
- Is the temperature sensor broken?
- Is mainboard broken?

Malfunction diagnosis process:

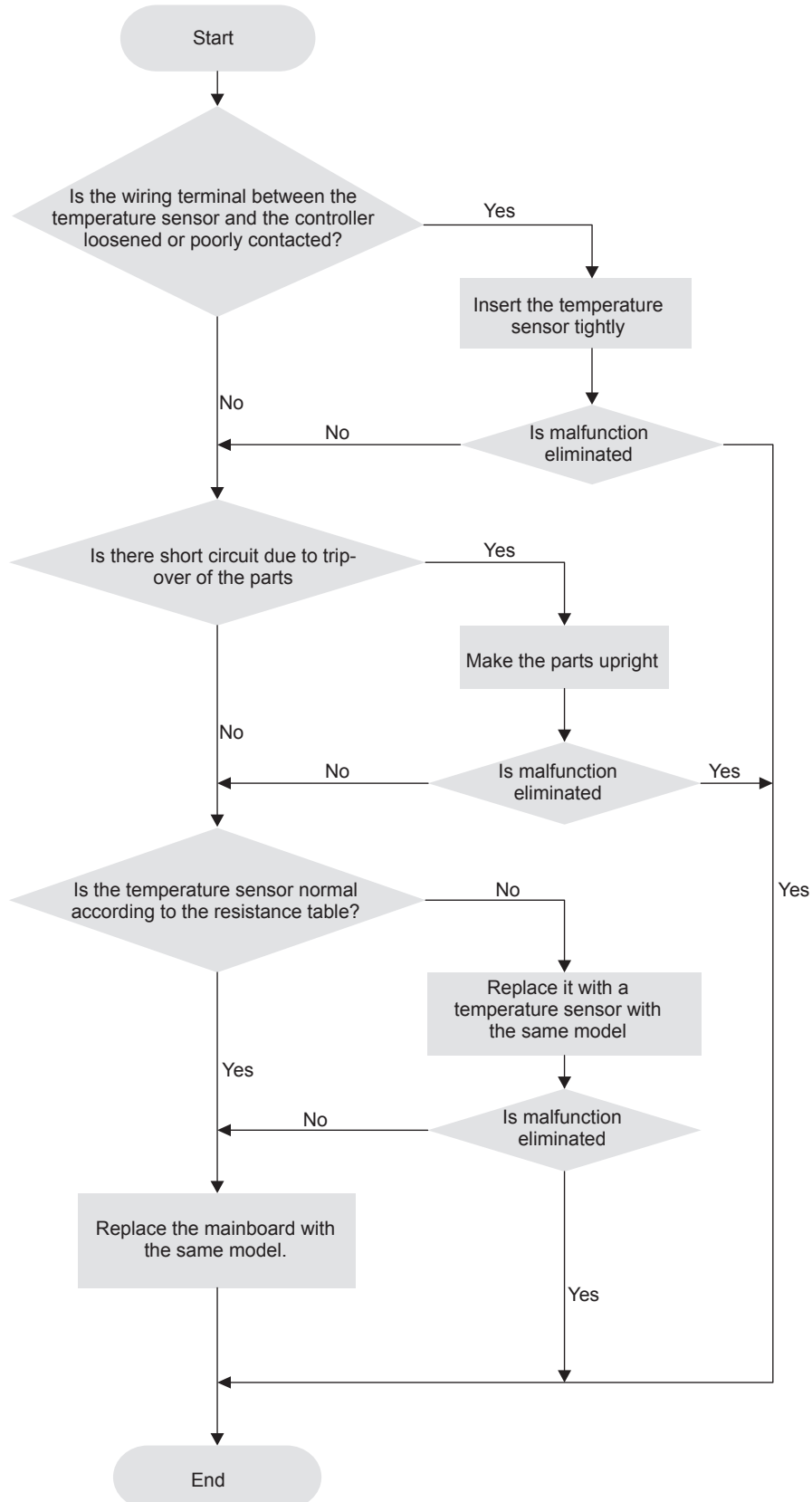

2. Communication malfunction E6

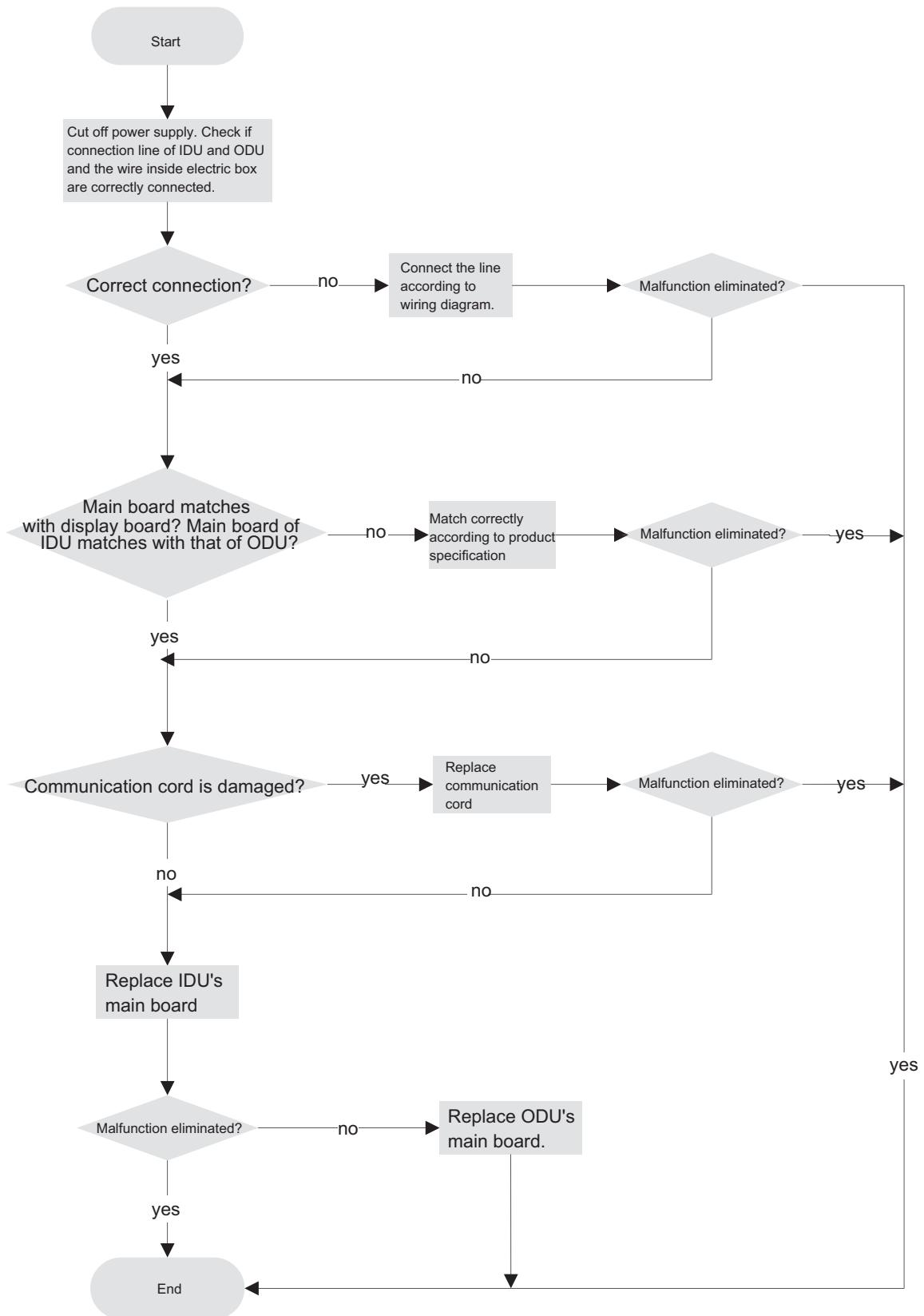

3. Full Water Protection E9

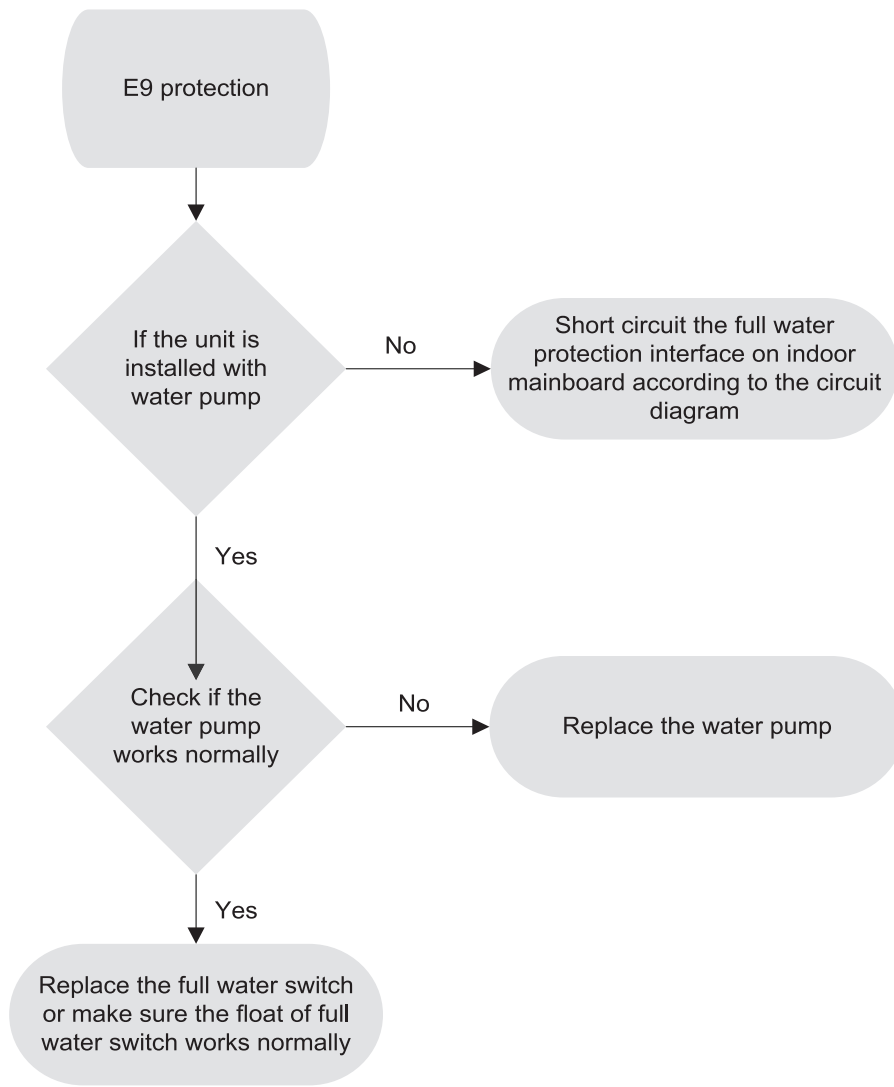

4. Malfunction of Insufficient fluorine protection F0

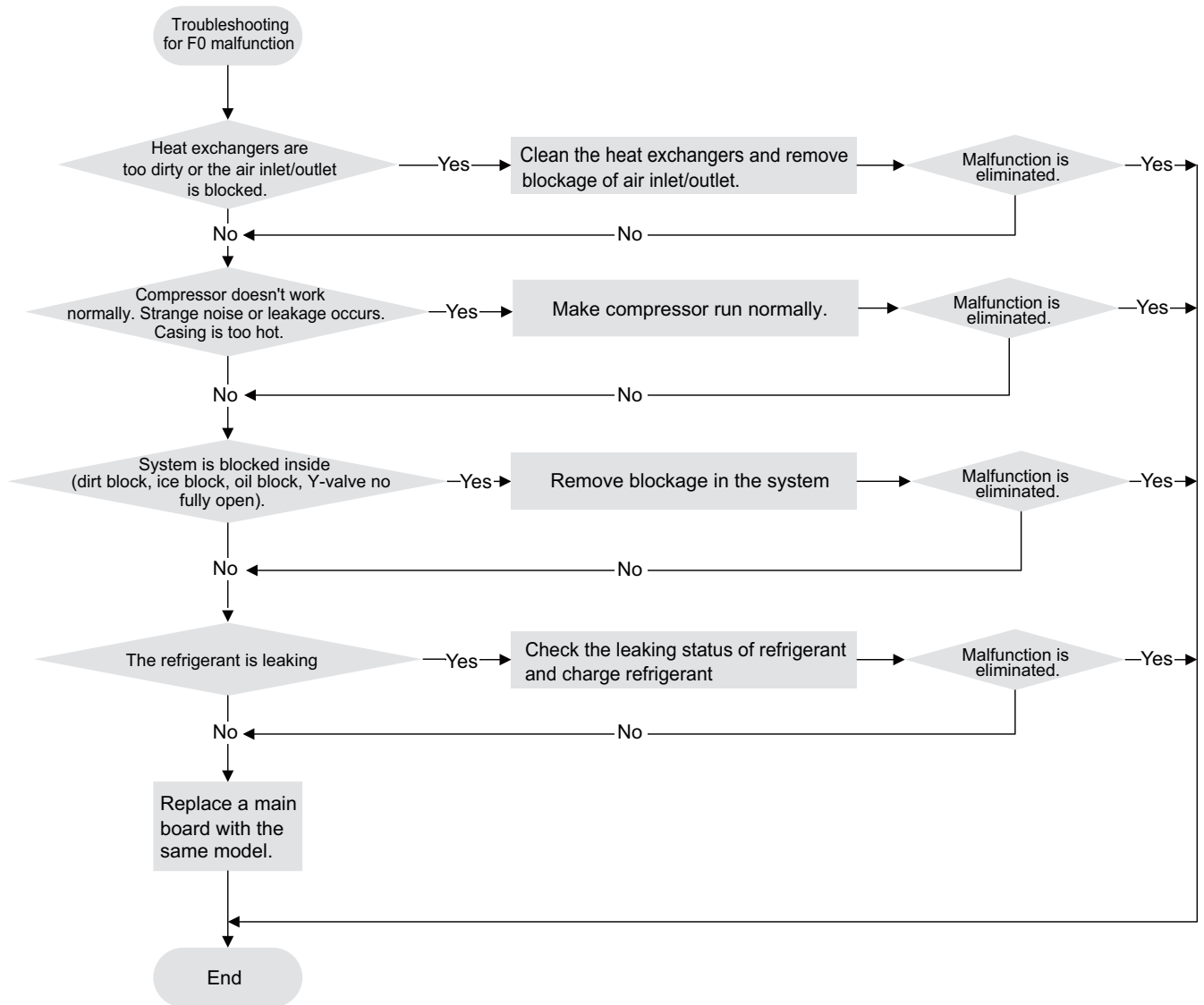

5. Malfunction of Blocked Protection of IDU Fan Motor H6

Main detection points:

- Smoothly the control terminal of PG motor connected tightly?
- Smoothly the feedback interface of PG motor connected tightly?
- The fan motor cant operate?
- The motor is broken?
- Detection circuit of the mainboard is defined abnormal?

Malfunction diagnosis process:

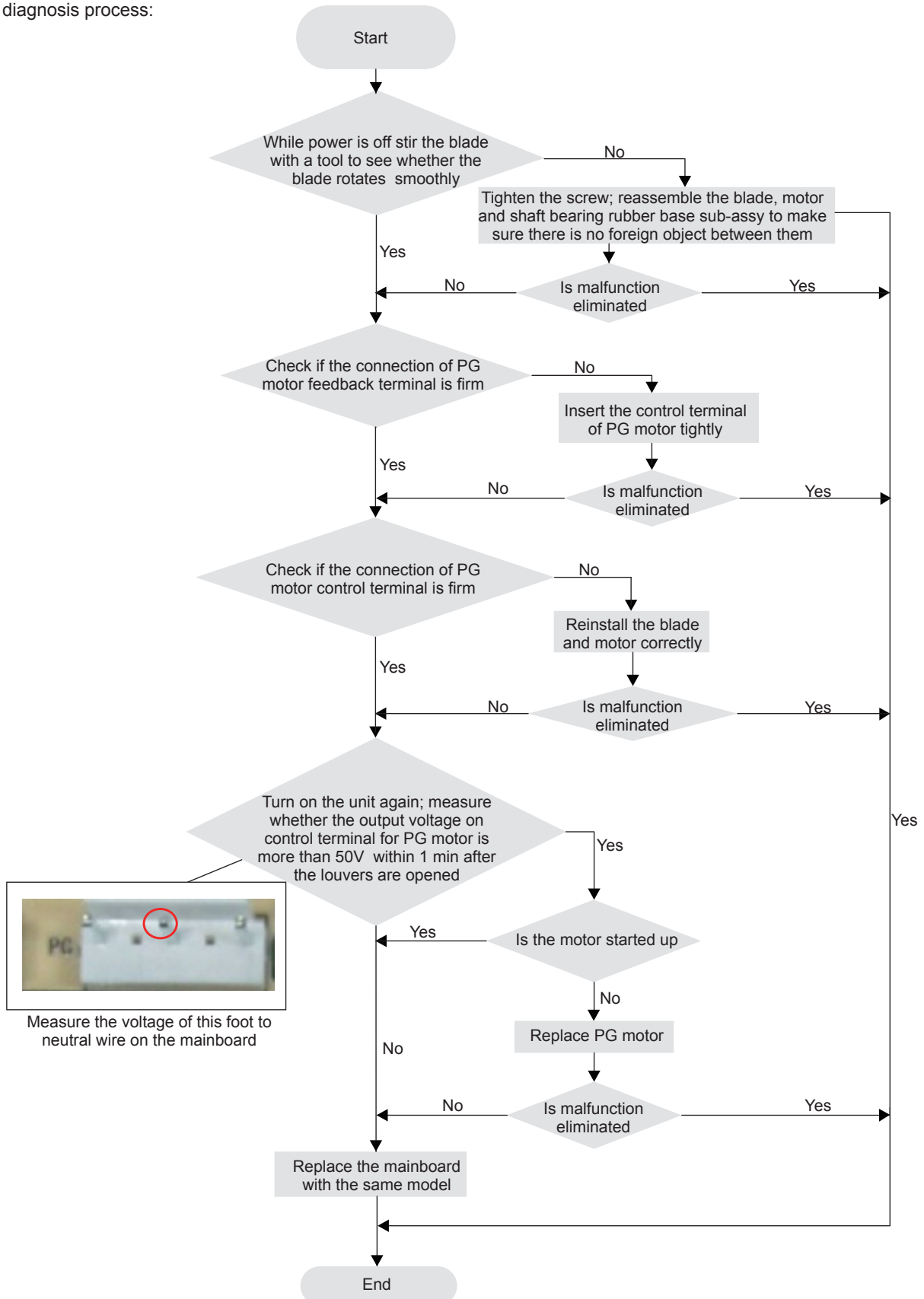

6. Malfunction of Protection of Jumper Cap C5

Main detection points:

- Is there jumper cap on the mainboard?
- Is the jumper cap inserted correctly and tightly?
- The jumper is broken?
- The motor is broken?
- Detection circuit of the mainboard is defined abnormal?

Malfunction diagnosis process:

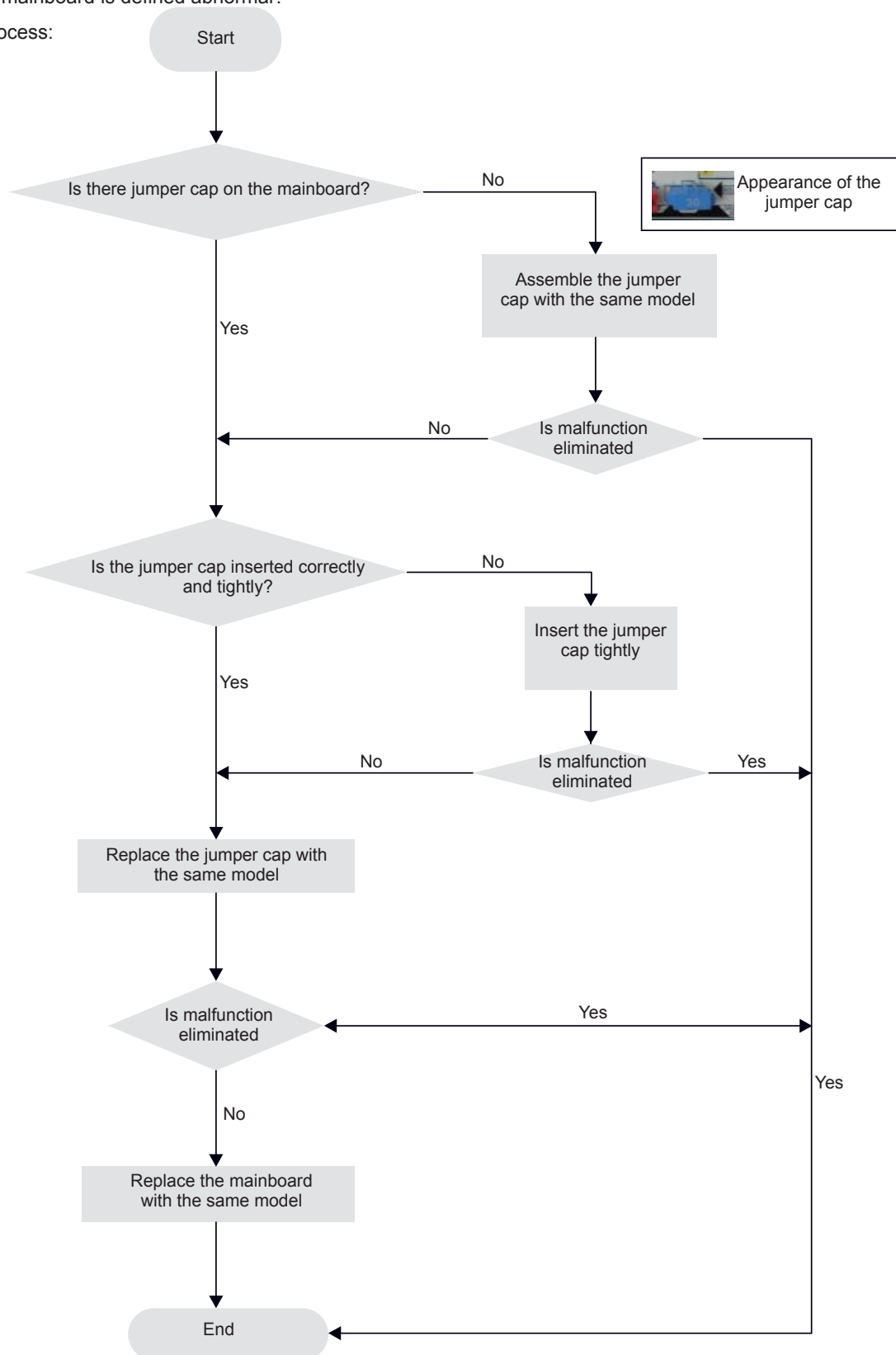

7. Malfunction of Zero-crossing Inspection Circuit Malfunction of the IDU Fan Motor U8

Main detection points:

- Instant energization after de-energization while the capacitor discharges slowly?
- The zero-cross detection circuit of the mainboard is defined abnormal?

Malfunction diagnosis process:

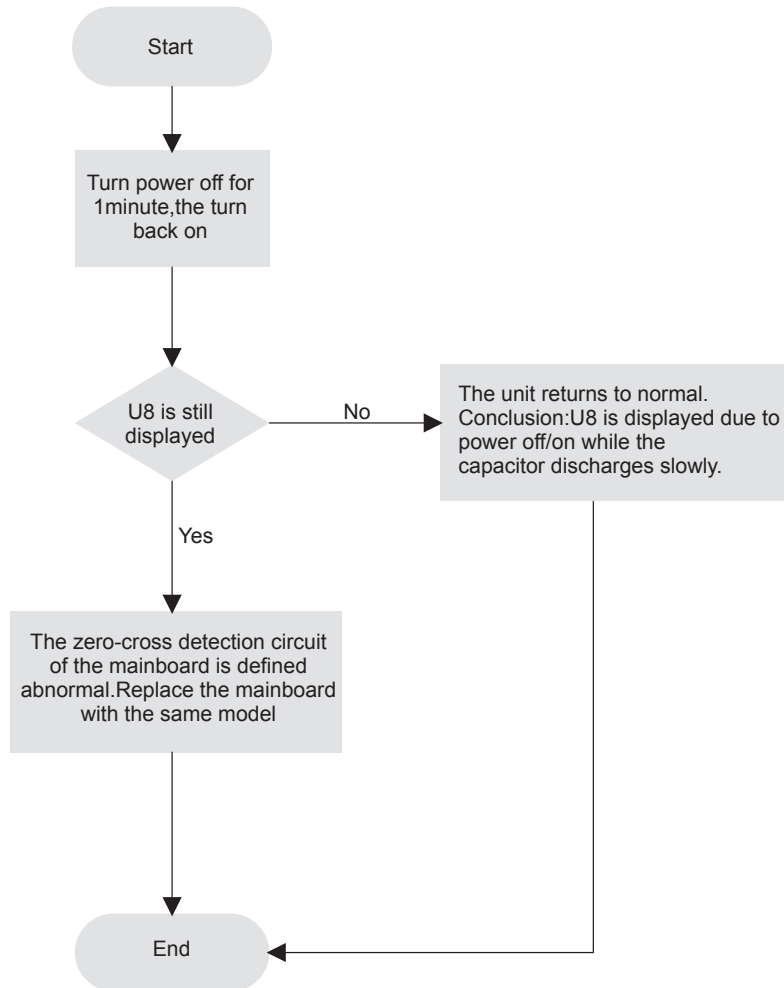

Outdoor Unit

1. Malfunction of Temperature Sensor (F3/F4/F5)

Main check point:

Whether the temperature sensor is damaged?

Whether the terminal of temperature sensor is loose or not connected?

Whether the main board is damaged?

Malfunction diagnosis process:

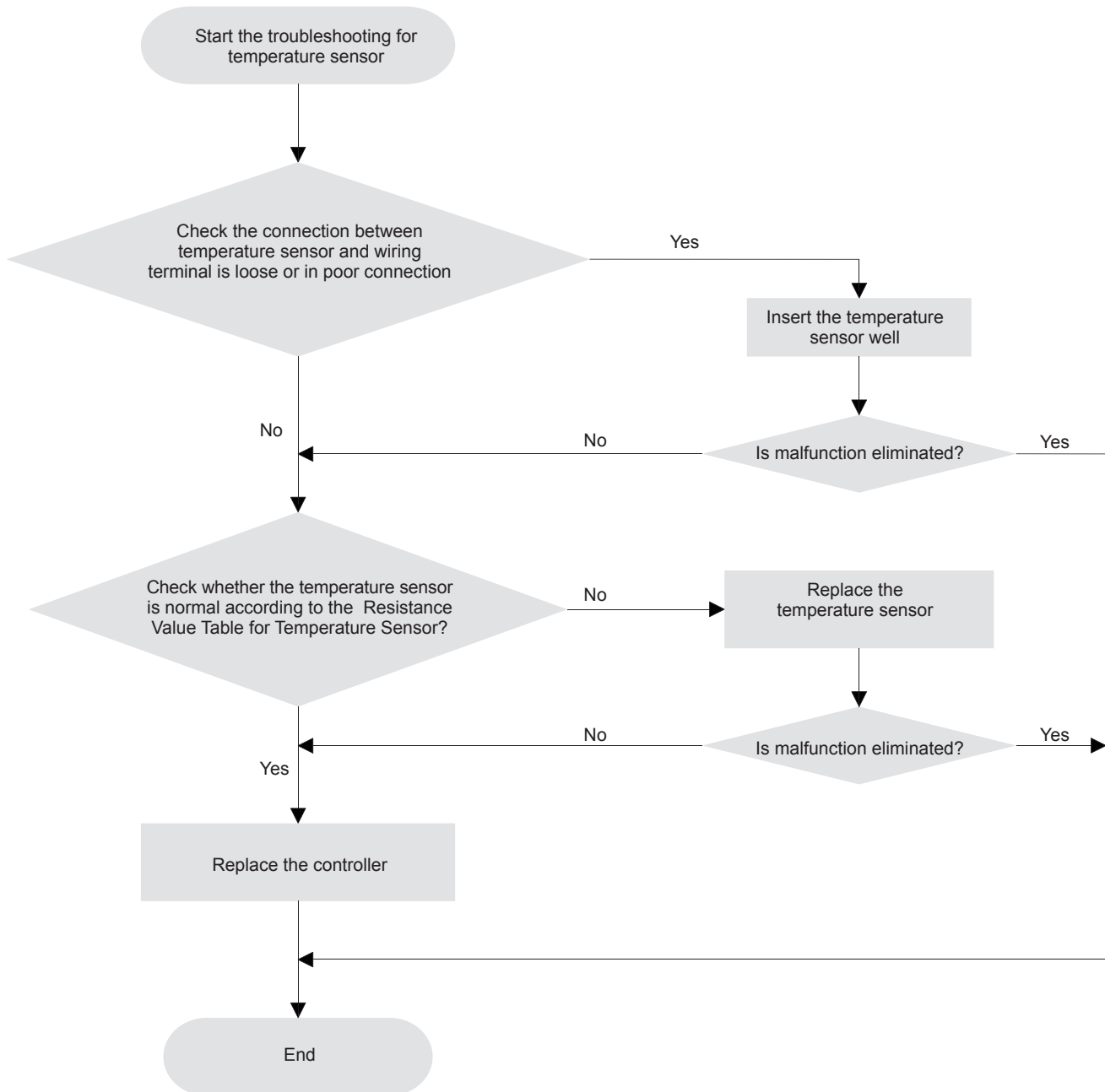

2. Malfunction of Overload Protection of Compressor (H3) and Discharge High-temperature Protection of Compressor (E4)

Main check point:

Whether the electronic expansion valve is connected well and whether its damaged?

Whether the refrigerant is leaking?

Whether the overload protector is damaged?

Malfunction diagnosis process:

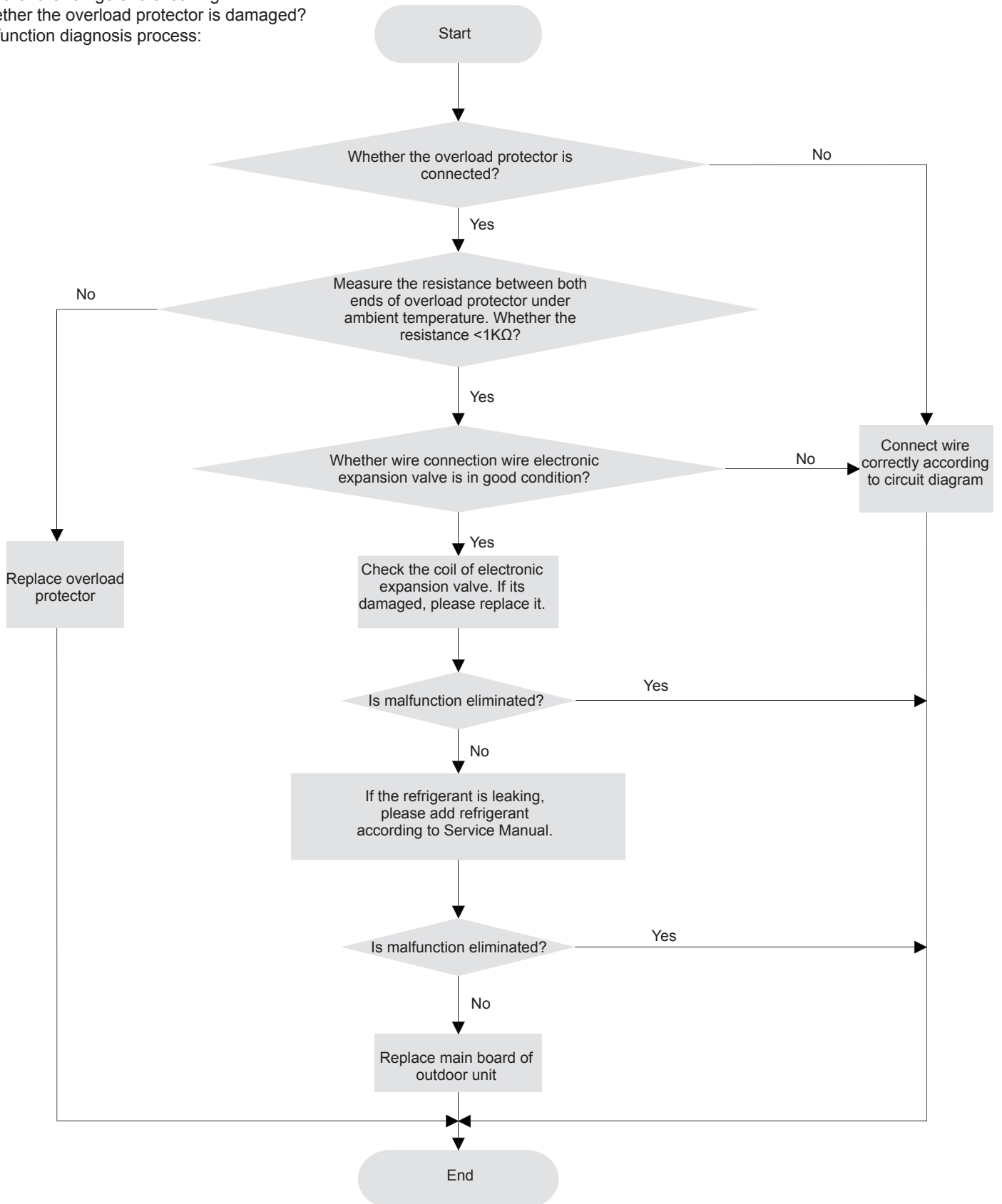

Remark:

Detection method for electronic expansion valve: There are 5 wires for the coil of electronic expansion valve and one of them are common port (the left or the right wire) .The resistance for other terminals are all most the same (about 100Ω). You can measure those resistance values to judge whether the electronic expansion valve is damaged or not.

3. Malfunction of Overload Protection (E8)

Main check point:

Whether the tube temperature sensor is normal?

Whether the outdoor ambient temperature is within the normal range?

Whether indoor fan and outdoor fan can operate normally?

Whether radiation environment inside or outside the unit is good?

Malfunction diagnosis process:

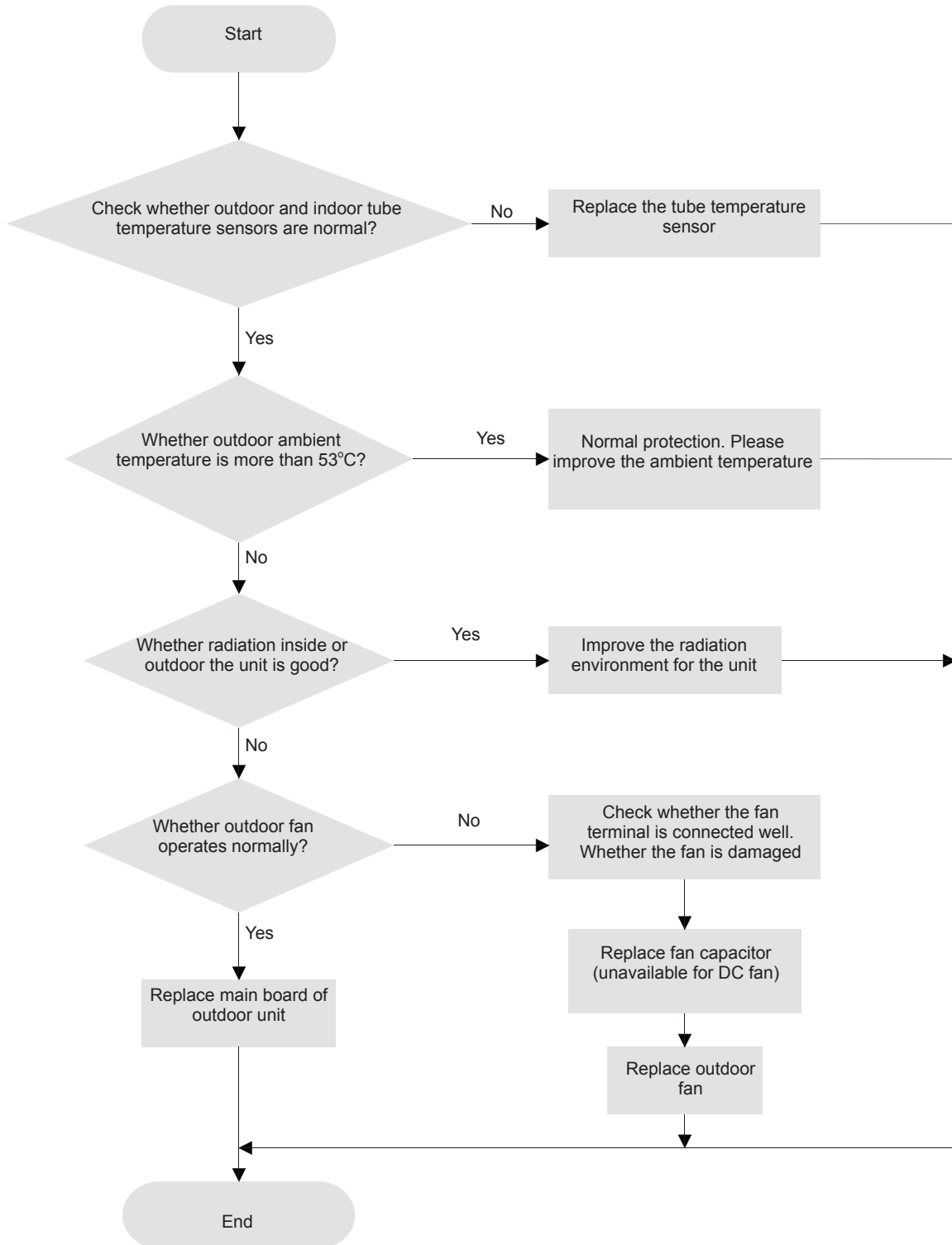

Remark:

When overload protection occurs under cooling mode, its because the main board detected the outdoor tube temperature sensor exceeds limited temperature and then the unit stops operation. Please check outdoor tube temperature sensor;

When overload protection occurs under heating mode, its because the main board detected the indoor tube temperature sensor exceeds limited temperature and then the unit stops operation. Please check indoor tube temperature sensor;

4. Malfunction of Overcurrent Protection E5

Main detection points:

- Is the supply voltage unstable with big fluctuation?
- Is the supply voltage too low with overload?
- Hardware trouble?

Malfunction diagnosis process:

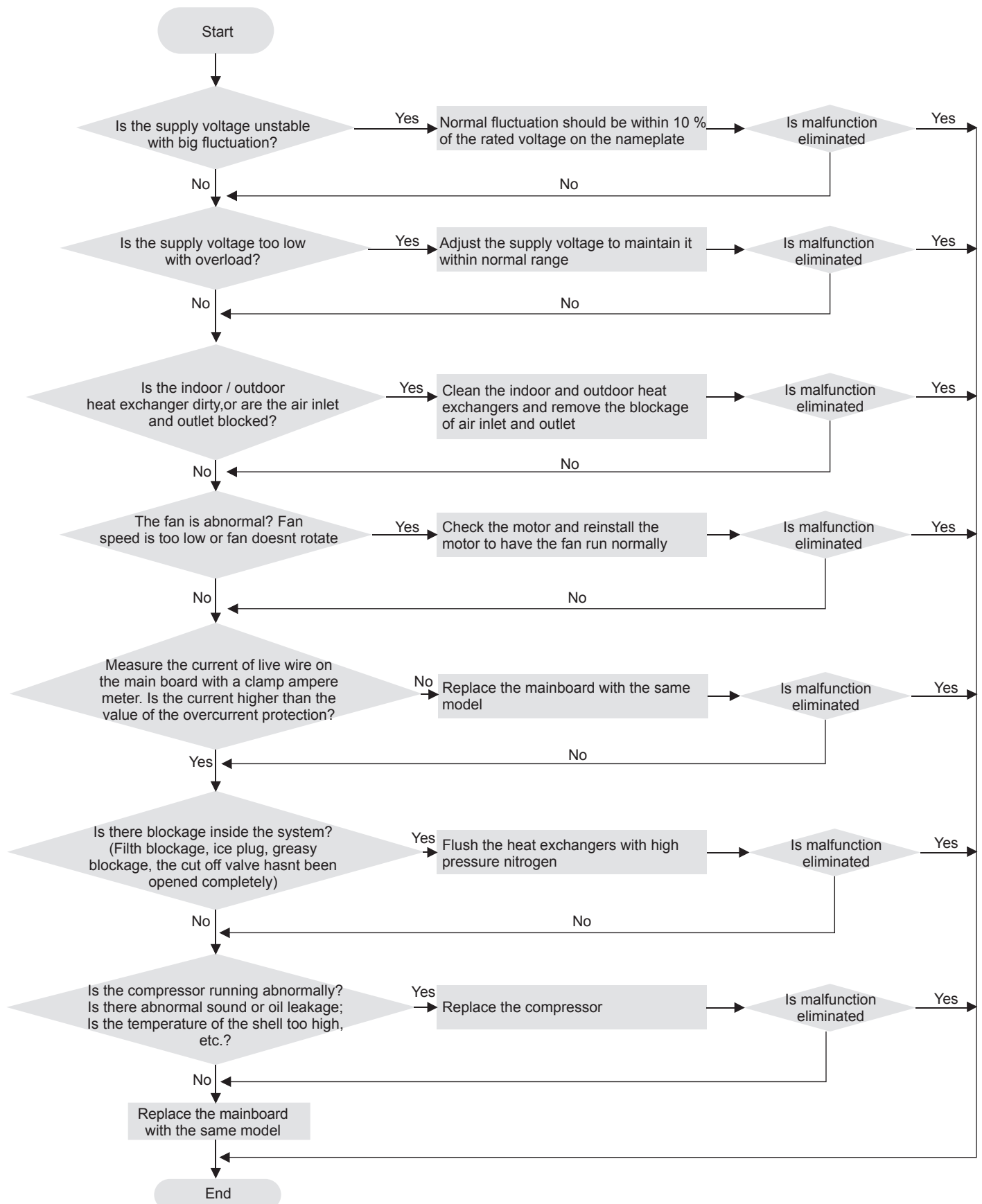

10. Exploded View and Parts List

MV-D09BI2, MV-D12BI2

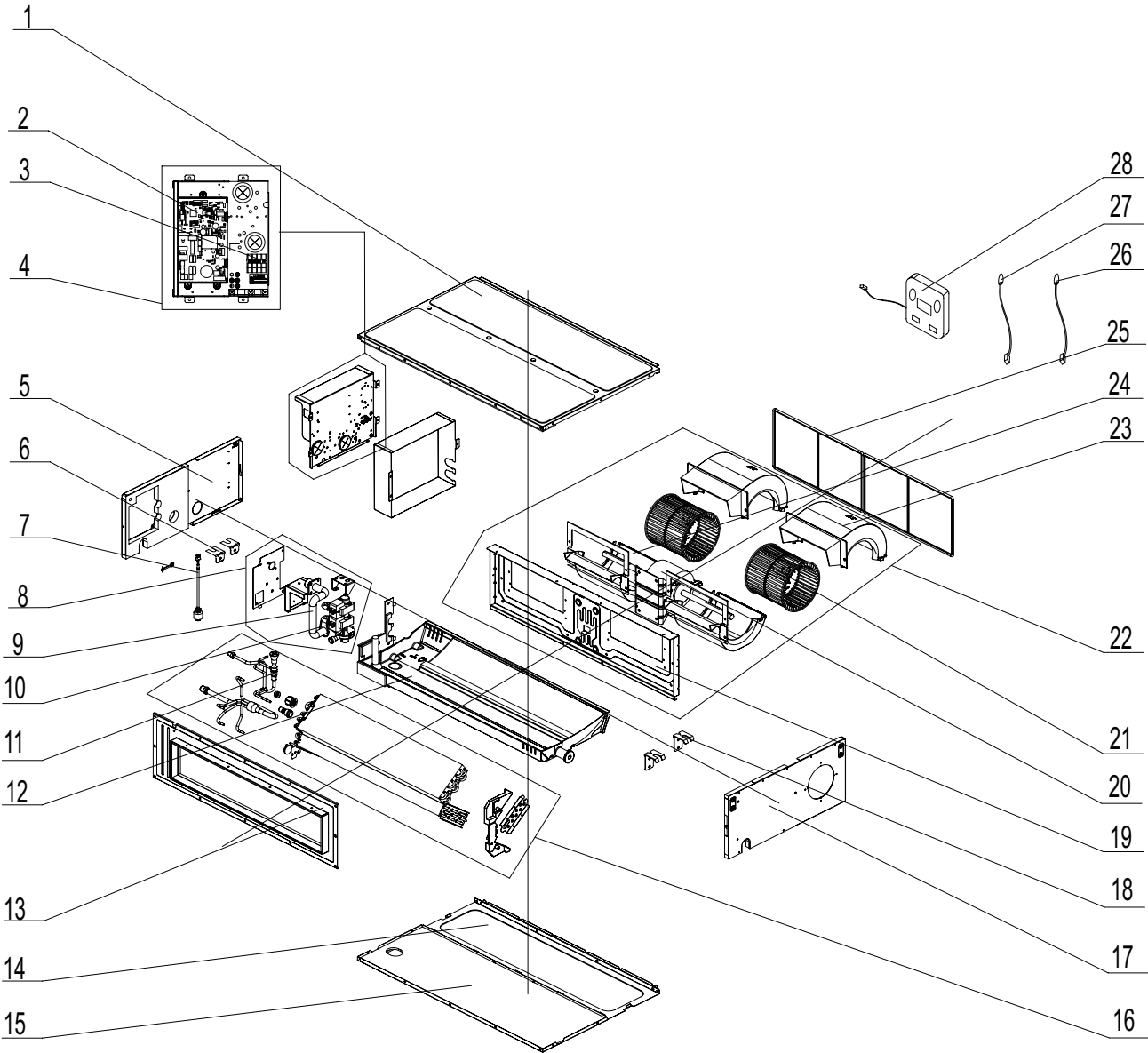

The component picture is only for reference; please refer to the actual product.

NO.	Description	Part Code MV-D09B12	Part Code MV-D12B12
1	Top Cover Board Assy	01265200066	01265200066
2	Main Board	300002061990	300002061990
3	Terminal Board	42000100000207	42000100000207
4	Electric Box assy	100002071511	100002071508
5	Left Side Plate Assy	000080000022	000080000022
6	Hook 2	01344100034	01344100034
7	Liquid Level Switch	430024000005	430024000005
8	Water Pump Assy	000104060066	000104060066
9	Drainage Pipe (Rubber)	760022000001	760022000001
10	Water Pump	81200706001605	81200706001605
11	Strainer	0721200102	0721200102
12	Water Tray Assy	01285200020	01285200020
13	Air Outlet Frame Assy	01374100057	01374100057
14	Cover Plate(Air return)	011657000030	011657000030
15	Bottom Cover Plate Assy	01264100102	01264100102
16	Evaporator Assy	011001061751	11001000474
17	Right Side Plate Assy	01315200053	01315200053
18	Hook	-	-
19	Blower Mounting Plate Sub-Assy	01325200034	01325200034
20	Fan Motor	1570520106	1570520106
21	Centrifugal fan	10425200003	10425200003
22	Centrifugal fan Assy	000052060176	000052060176
23	Propeller Housing(Upper)	26905200018	26905200018
24	Propeller Housing(Lower)	26905200019	26905200019
25	Filter Sub-Assy	111001000082	111001000082
26	Temperature Sensor	390000597	390000597
27	Ambient Temperature Sensor	390000453	390000453
28	Display Board	300001060893	300001060893

Some models may not contain some parts, please refer to the actual product.

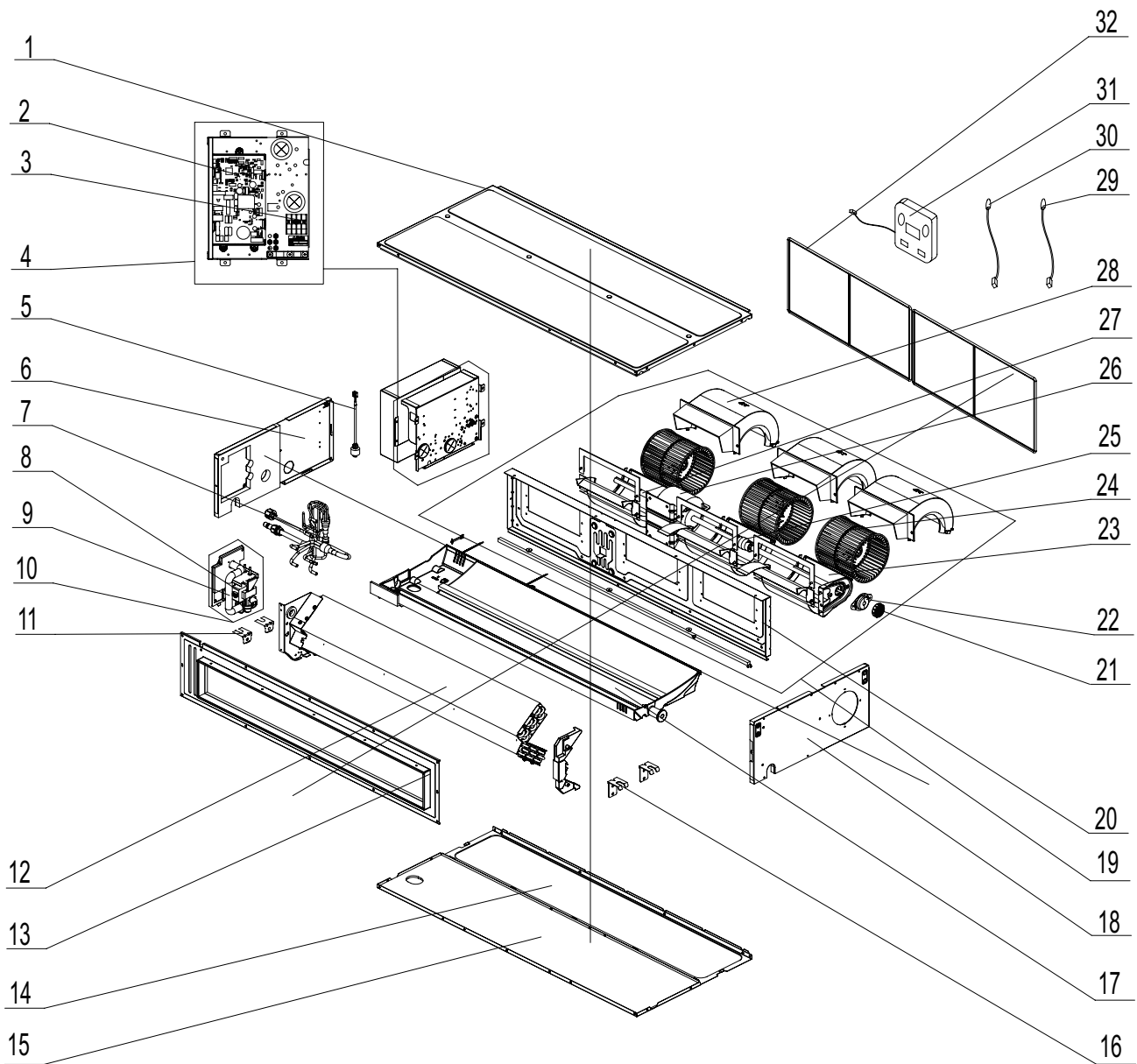

The component picture is only for reference; please refer to the actual product.

NO.	Description	Parts code
1	Top Cover Board Assy	01265200068
2	Main Board	300002061990
3	Terminal Board	42000100000207
4	Electric Box assy	100002071505
5	Liquid Level Switch	430024000005
6	Left Side Plate Assy	000080000022
7	Strainer	0721200102
8	Water Pump	81200706001605
9	Drainage Pipe (Rubber)	760022000001
10	Water Pump Assy	000104060066
11	Hook 2	01344100034
12	Evaporator Assy	011001000506
13	Air Outlet Frame Assy	01374100058
14	Cover of Air-In	01265200073
15	Bottom Cover Plate Assy	01264100103
16	Hook	-
17	Water Tray Assy	01285200022
18	Right Side Plate Assy	01315200053
19	Centrifugal fan Assy	000052000076
20	Blower Mounting Plate Sub-Assy	01325200035
21	Bearing Holder Sub-Assy	26151139
22	Support of Motor Motor	02285200001
23	Propeller Housing(Lower)	26905200019
24	Centrifugal fan	10425200003
25	Joint Slack	73018731
26	Brushless DC Motor	1570520106
27	Rotary Axis Sub-Assy	73018761
28	Propeller Housing(Upper)	26905200018
29	Temperature Sensor	390000597
30	Room Sensor	390000453
31	Display Board	300001060893
32	Filter Sub-Assy	111253038

Some models may not contain some parts, please refer to the actual product.

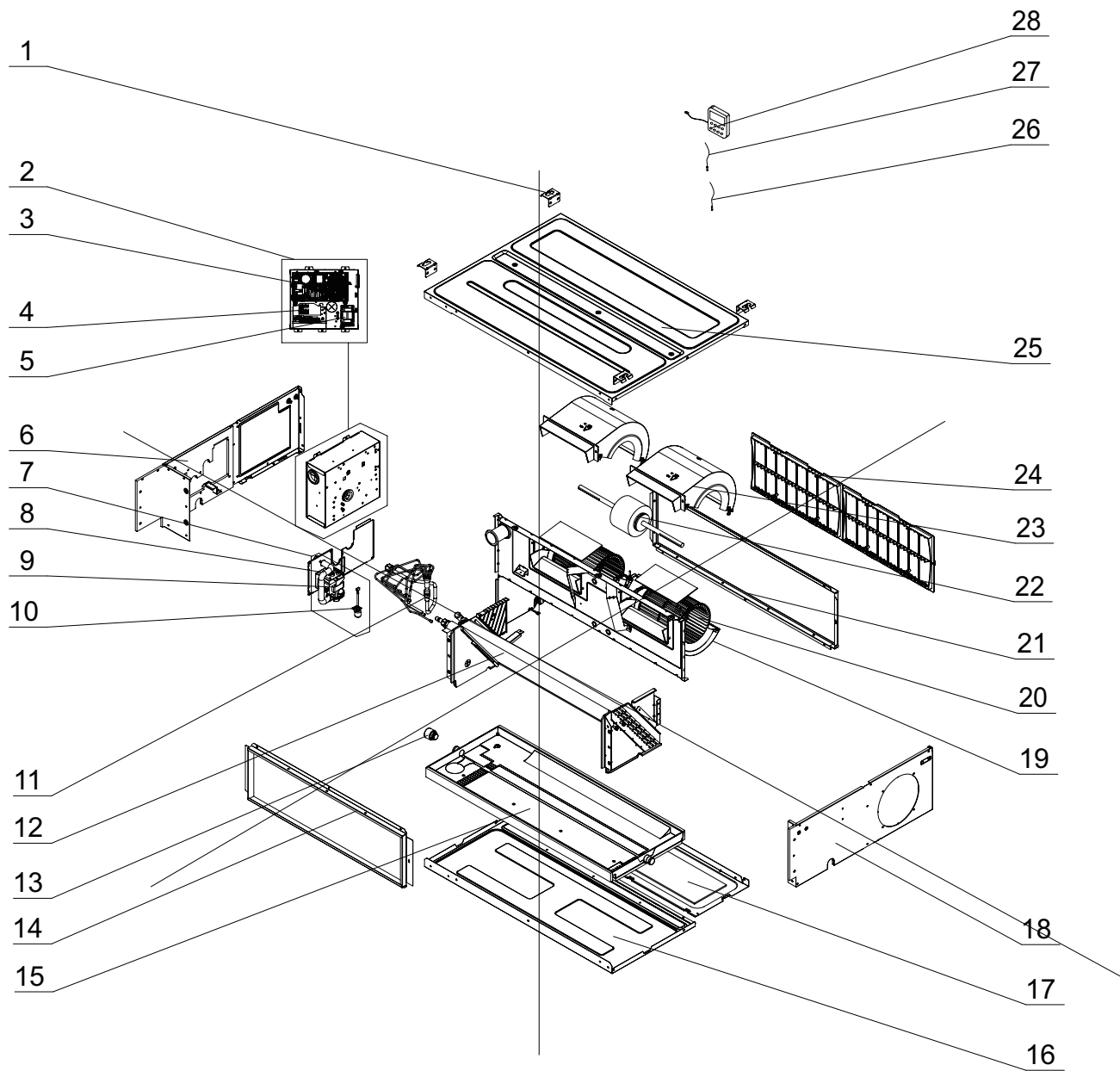

The component picture is only for reference; please refer to the actual product.

NO.	Description	Part Code
1	Hook	012045060010
2	Electric Box assy	100002071510
3	Main Board	300002061990
4	Terminal Board	42000100000207
5	Filter Board	-
6	Left Side Plate	017037060139
7	Water Pump Assy	000104060048
8	Drainage Pipe (Rubber)	760022000001
9	Water Pump	81200706001601
10	Liquid Level Switch	430024000005
11	Strainer	0721212101
12	Evaporator Assy	011001061753
13	Rubber Plug	768152000002
14	Air Outlet Frame Assy	000141060058
15	Water Tray	000069060293
16	Bottom Cover Plate	012147060082
17	Cover of Air-In	012104060002
18	Right Side Plate	017038060169
19	Volute Casing	200230060004
20	Centrifugal fan	103003060003
21	Air intake Side Board Sub-Assy	017040060003
22	Brushless DC Motor	150101060407
23	Volute Casing	200230060003
24	Filter Sub-Assy	111001060189
25	Top Cover	000132060053
26	Temperature Sensor	390000596
27	Temperature Sensor	390000451
28	Display Board	300001060893

Some models may not contain some parts, please refer to the actual product.

11. Removal Procedure



Caution: discharge the refrigerant completely before removal.

09/12K

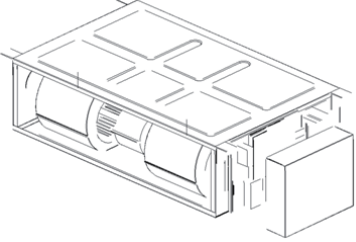
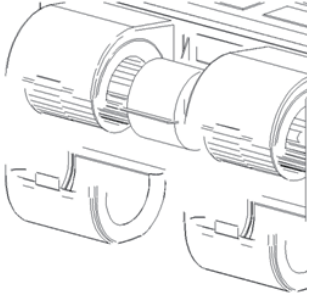
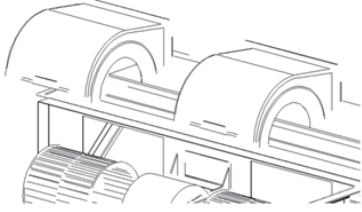
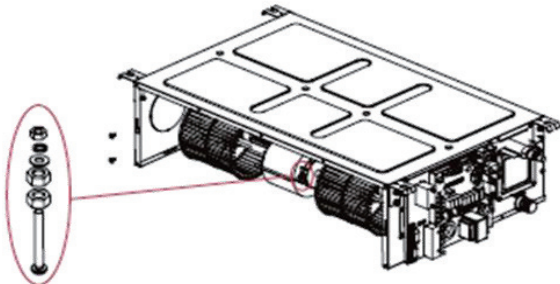
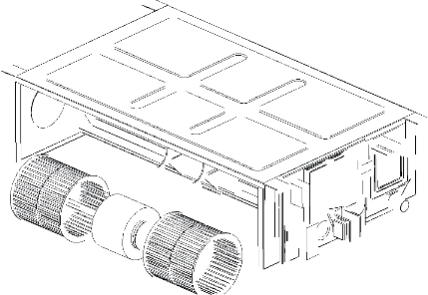
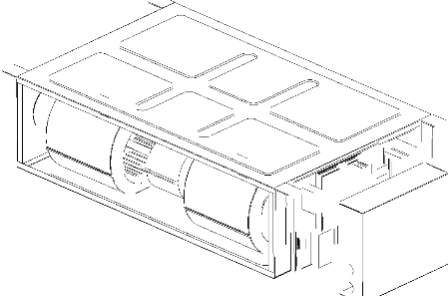
Step	Diagram	Operation Procedure
<p>1. Remove the cover plate of the electric box.</p>		<ul style="list-style-type: none"> ● Disconnect the power supply of the IDUs, use a screwdriver to unscrew the cover plate of the electric box, and then remove the line connecting to the motor.
<p>2. Remove the rear volute casing.</p>		<ul style="list-style-type: none"> ● Loosen the fasteners that connect the rear volute casing with the front volute casing and remove the rear volute casing.
<p>3. Remove the front volute casing.</p>		<ul style="list-style-type: none"> ● Use a screwdriver to unscrew the front volute casing and then remove the volute casing.
<p>4. Remove the louver and motor.</p>		<ul style="list-style-type: none"> ● Use a screwdriver to unscrew the louver and loosen the fasteners of the motor.
<p>5. Install a new motor.</p>		<ul style="list-style-type: none"> ● Remove the motor from the support and remove the louver from the motor. Then, remove the motor. ● Install a new motor.
<p>6. Install units in a reverse order of this procedure.</p>		<ul style="list-style-type: none"> ● Assemble units based on the reverse order of this procedure and power on the units for test.

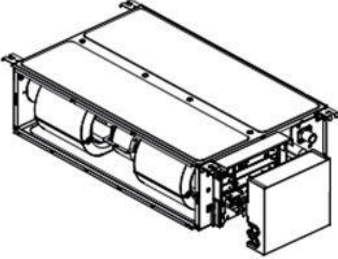
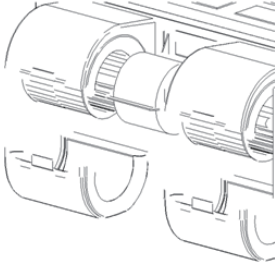
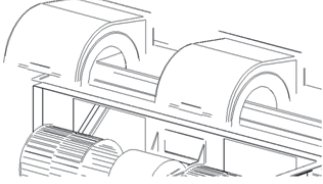
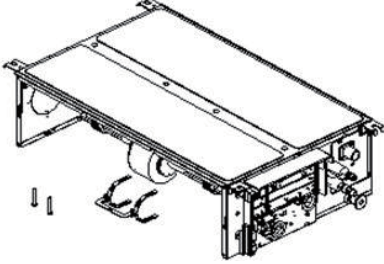
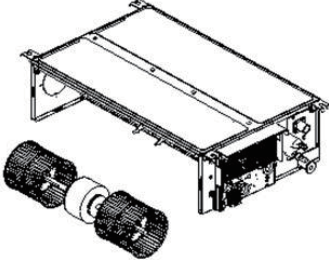
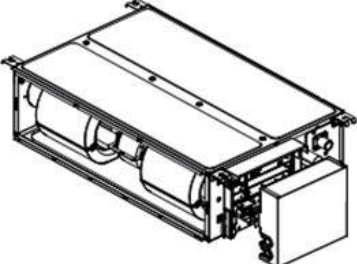
Step	Diagram	Operation Procedure
<p>1. Remove the air return filter.</p>		<ul style="list-style-type: none"> ● Draw the air return filter to both sides respectively at the return air inlet.
<p>2. Remove the cover plate of the electric box.</p>		<ul style="list-style-type: none"> ● Disconnect the power supply of the IDUs, use a screwdriver to unscrew the cover plate of the electric box, and then remove the line connecting to the motor.
<p>3. Remove the rear volute casing.</p>		<ul style="list-style-type: none"> ● Loosen the fasteners that connect the rear volute casing with the front volute casing and remove the rear volute casing.
<p>4. Remove the front volute casing.</p>		<ul style="list-style-type: none"> ● Use a screwdriver to unscrew the front volute casing and then remove the volute casing.
<p>5. Remove the louver and motor.</p>		<p>Use a screwdriver to unscrew the louver and loosen the fasteners of the motor.</p>
<p>6. Install a new motor.</p>		<ul style="list-style-type: none"> ● Remove the motor from the support and remove the louver from the motor. Then remove the motor. ● Install a new motor.
<p>7. Install units in a reverse order of this procedure.</p>		<ul style="list-style-type: none"> ● Assemble units based on the reverse order of this procedure and power on the units for test.

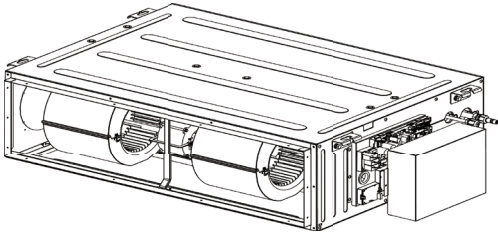
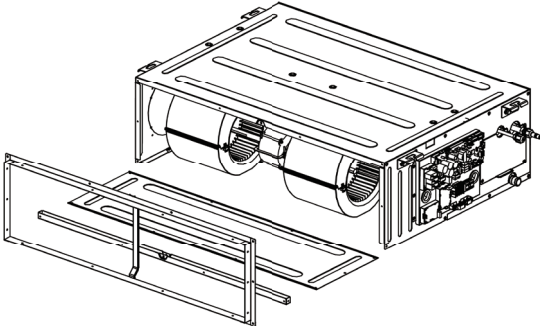
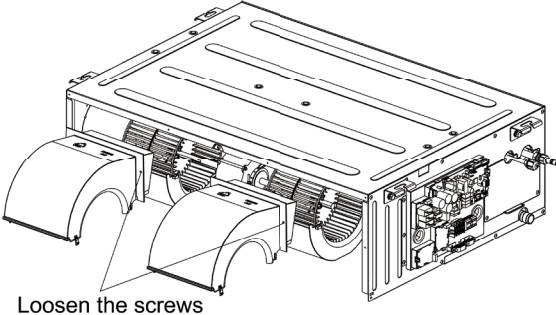
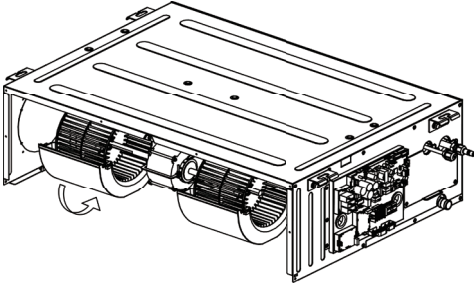
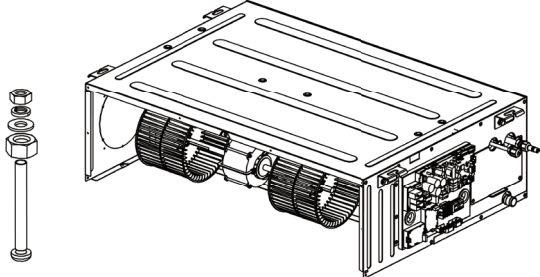
Removal of fan and motor		
Note: Before removing the motor, make sure power is cut off.		
Step	Picture	Work instruction
1. Remove the cover of electric box.		Turn off the power supply of indoor unit. Use a screwdriver to remove the cover of electric box. Disconnect the motor wire inside the electric box.
2. Remove air return plate, the longitudinal component and air return frame.		Use a hex wrench to loosen the screws of fan. Order of removal: air return plate, air return frame, longitudinal component, cross beam.
3. Remove the upper volute.	 Loosen the screws	Loosen the screws of upper volute and then pull out the upper volute.
4. Remove the lower volute.		Loosen the screws of lower volute and then rotate in the direction shown by the arrow.
5. Remove the motor and fan.		Use a screwdriver to remove the clamping band of motor. Then remove the motor and fan as a whole.

Removal of fan and motor

Note: Before removing the motor, make sure power is cut off.

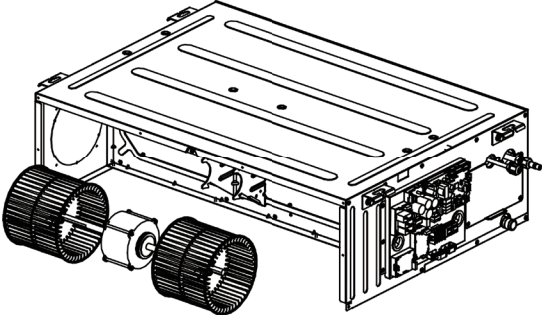
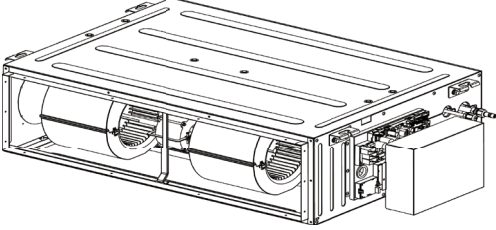
Step	Picture	Work instruction
6. Replace the motor.		Remove the motor from the motor support. Use a hex wrench to loosen the screws of fan. Remove the fan from the motor. Replace with a new motor.
7. Re-install the device in a reverse order of the removal procedure.		Re-install the device in a reverse order of the removal procedure. Then connect power and test it.

Removal of air return filter

Note: Before removal, make sure power is cut off. During the removal procedure, take good care of all the components. Do not place the filter near any heat source.

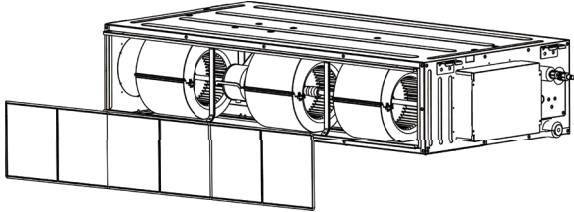
Step	Picture	Work instruction
Remove air return filter.		Press the air return filters on the guideway sponge. There are 2 or 3 air return filters.

Removal of the cover of electric box and the electric box

Note: Before removal, make sure power is cut off. During the removal procedure, take good care of all the components, especially the electric components. Do not hit or beat.

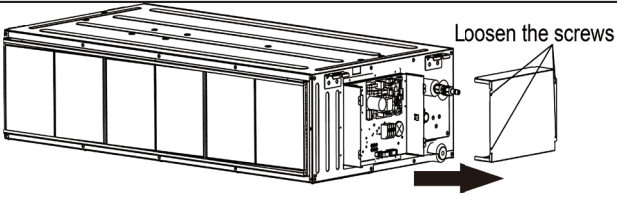
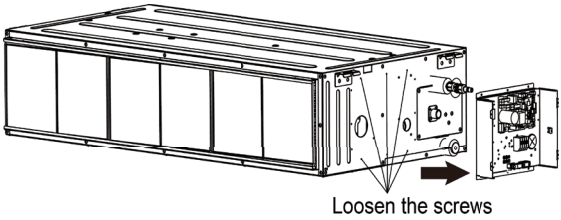
Step	Picture	Work instruction
1. Remove the cover of electric box.		Loosen the screws as shown by the circle and the box. Remove the box in the direction shown by the arrow.
2. Remove the electric box.		Loosen the securing screws and remove the electric box.

Removal of water tray

Note: Before removal, make sure power is cut off. During the removal procedure, take good care of all the components.

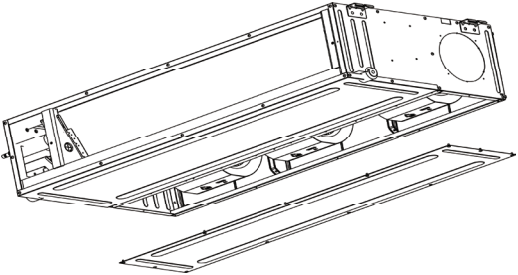
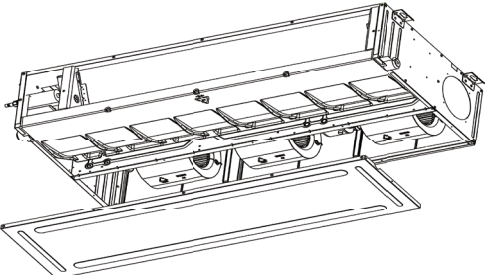
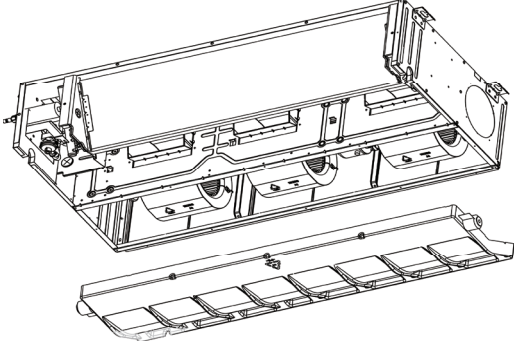
Step	Picture	Work instruction
1. Remove the cover plate.		Loosen the screws of cover plate and then remove the cover plate. (As shown in the picture, the circle indicates 6 screws of the cover plate.)
		
2. Remove the water tray.		Loosen the screws of water trap. Pull it up and remove it. The removed water tray is as shown in the picture.

Removal of evaporator

Note: Make sure power is cut off. Take good care of the copper pipe and aluminum fins. If the removal takes a long time, please put the copper pipe under pressure.

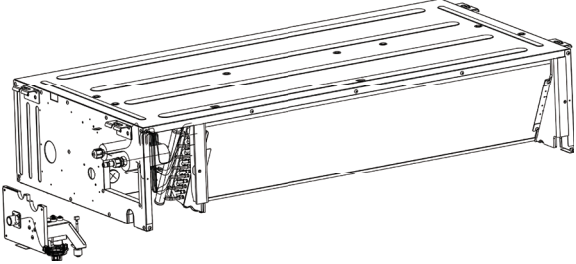
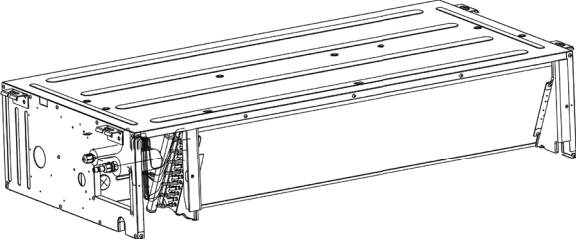
Step	Picture	Work instruction
1. Remove the screws on the side plate of evaporator.		Remove the screws of evaporator and the screws that connect the upper cover plate to the left and right side plates.
2. Remove the sealing plate the connects to the evaporator valve and the screws that connect to the flange.		Remove the screws of the sealing plate of valve. Then remove the sealing plate of valve. Remove the screws that connect the evaporator to the flange.

Removal of evaporator

Note: Make sure power is cut off. Take good care of the copper pipe and aluminum fins. If the removal takes a long time, please put the copper pipe under pressure.

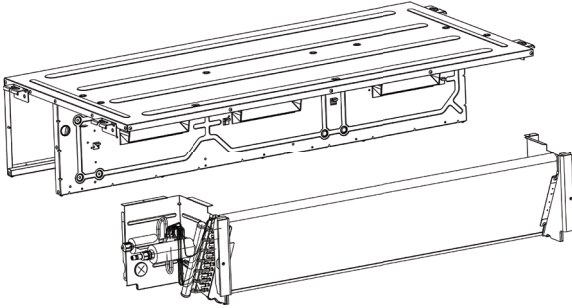
Step	Picture	Work instruction
3. Remove the evaporator.		Take off the evaporator. The removed evaporator is as shown in the picture.

NOTE CONCERNING PROTECTION OF ENVIRONMENT



This product must not be disposed of via normal household waste after its service life, but must be taken to a collection station for the recycling of electrical and electronic devices. The symbol on the product, the operating instructions or the packaging indicate such disposal procedures. The materials are recyclable in accordance with their respective symbols. By means of re-use, material recycling or any other form of recycling old appliances you are making an important contribution to the protection of our environment. Please ask your local council where your nearest disposal station is located.

INFORMATION CONCERNING USED REFRIGERANT MEDIUM

This unit is containing fluorinated gases included in the Kyoto protocol.
The maintenance and the liquidation must be carried out by qualified personnel.

Type of refrigerant: R32

The quantity of the refrigerant: Please see the unit label.

The value GWP: 675 (1 kg R32 = 0,675 t CO₂ eq)

GWP = Global Warming Potential



Appliance filled with flammable gas R32.

In case of quality problem or other please contact your local supplier or authorized service center.

Emergency number: 112

PRODUCER

SINCLAIR CORPORATION Ltd.

1-4 Argyll St.

London W1F 7LD

Great Britain

www.sinclair-world.com

This product was manufactured in China (Made in China).

REPRESENTATIVE

SINCLAIR Global Group s.r.o.

Purkynova 45

612 00 Brno

Czech Republic

TECHNICAL SUPPORT

SINCLAIR Global Group s.r.o.

Purkynova 45

612 00 Brno

Czech Republic

Tel.: +420 800 100 285 | Fax: +420 541 590 124

www.sinclair-solutions.com | info@sinclair-solutions.com



